



Inspired by **temperature**

Unical[®] 700

Installation Guide

huber



INSTALLATION GUIDE

Unical® 700

Unical[®] 700

This installation guide is a translation of the original German installation guide.

VALID IN CONJUNCTION WITH:

Huber temperature control units of the
Unistat[®] series

Table of contents

V1.1.0en/07.08.19

1	Introduction	10
1.1	Safety	10
1.1.1	Symbols used for Safety Instructions.....	10
1.1.2	Representation of safety identifiers	11
1.1.3	Safety during commissioning.....	11
1.1.4	Extension of specified normal operation.....	11
1.2	Responsible bodies and operators – Obligations and requirements	12
1.2.1	Obligations of the responsible body	12
1.2.1.1	Proper disposal of resources and consumables	12
1.2.2	Requirements for operators	13
1.2.3	Obligations of the operators.....	13
1.3	General information	13
1.3.1	Description of workstation	13
2	Commissioning	14
2.1	In-plant transport	14
2.1.1	Lifting and transporting the accessories	14
2.1.1.1	Accessories with lifting eyes.....	14
2.1.1.2	Accessories without lifting eyes	14
2.2	Unpacking	14
2.3	Ambient conditions	15
2.4	Installation conditions	16
2.5	Recommended temperature control hoses	16
2.6	Wrench sizes and torques	17
2.7	Preparations for operation	17
2.7.1	Unscrewing/activating the leveling feet (if any)	17
2.7.2	Checking the knurled screws	17
2.7.3	Installing collecting container	18
2.8	Connecting the accessory to the temperature control unit	18
3	Function description	19
3.1	Function description of the accessory	19
3.1.1	General functions.....	19
3.2	To be noted when planning the test	19
4	Setup mode	20
4.1	Setup mode	20
4.1.1	Setting the setpoint	20
4.2	Filling and draining the accessory	20
4.2.1	Filling the accessory	21
4.2.2	Draining the accessory.....	22
4.2.3	Draining the overflow vessel.....	22
5	Normal operation	23
5.1	Automatic operation	23
5.1.1	Temperature control.....	23
5.1.1.1	Starting the temperature control process.....	23

5.1.1.2	Ending the temperature control process	23
6	Service/maintenance	24
6.1	Maintenance.....	24
6.1.1	Function check and visual inspection	24
6.1.2	Replacing temperature control hoses.....	24
6.1.3	Drain the collecting container.....	25
6.2	Thermal fluid inspection, replacement and circuit cleaning.....	25
6.3	Cleaning the surfaces	25
6.4	Decontamination/repairs	25
7	Shutting down	26
7.1	Safety instructions and basic principles	26
7.2	Switch-off	26
7.3	Draining the accessory	26
7.4	Dismantling the collecting container.....	27
7.5	Separating the accessory from the temperature control unit	27
7.6	Packing	27
7.7	Shipping.....	27
7.8	Disposal	28
7.9	Contact data	28
7.9.1	Telephone number: Customer Support	28
7.9.2	Telephone number: Sales	28
7.9.3	Email address: Customer Support.....	28
7.10	Certificate of Compliance	28
8	Annex	29

Foreword

Dear Customer,

Thank you for choosing a calibration bath from Peter Huber Kältemaschinenbau SE. You have made a good choice. Thank you for your trust.

Please read the installation guide carefully before putting the unit into operation. Strictly follow all notes and safety instructions.

Follow the installation guide with regard to transport, start-up, operation, maintenance, repair, storage and disposal of the calibration bath.

We fully warrant the calibration bath for the specified intended operation.

The models listed on page 5 are referred to in this installation guide as accessory and Peter Huber Kältemaschinenbau SE as Huber company or Huber.

Liability for errors and misprints excluded.

The following trademarks and the Huber logo are registered trademarks of Peter Huber Kältemaschinenbau SE in Germany and/or other countries worldwide: BFT®, CC®, CC-Pilot®, Com.G@te®, Compatible Control®, CoolNet®, DC®, E-grade®, Grande Fleur®, KISS®, Minichiller®, Ministat®, MP®, MPC®, Peter Huber Minichiller®, Petite Fleur®, Pilot ONE®, RotaCool®, Rotostat®, SpyControl®, SpyLight®, Tango®, TC®, UC®, Unical®, Unichiller®, Unipump®, Unistat®, Unistat-Pilot®, Unistat Tango®, Variostat®, Web.G@te®. The following trademarks are registered in Germany to DWS Synthesetechnik: DW-Therm®, DW-Therm HT®

1 Introduction

1.1 Safety

1.1.1 Symbols used for Safety Instructions

Safety instructions are marked by the below combinations of pictograms and signal words. The signal word describes the classification of the residual risk when disregarding the installation guide.



DANGER
Denotes an immediate hazardous situation that will result in death or serious injuries.



WARNING
Denotes a general hazardous situation that may result in death or serious injuries.



CAUTION
Denotes a hazardous situation that can result in injury.



NOTE
Denotes a situation that can result in property material damage.



INFORMATION
Denotes important notes and usable hints.



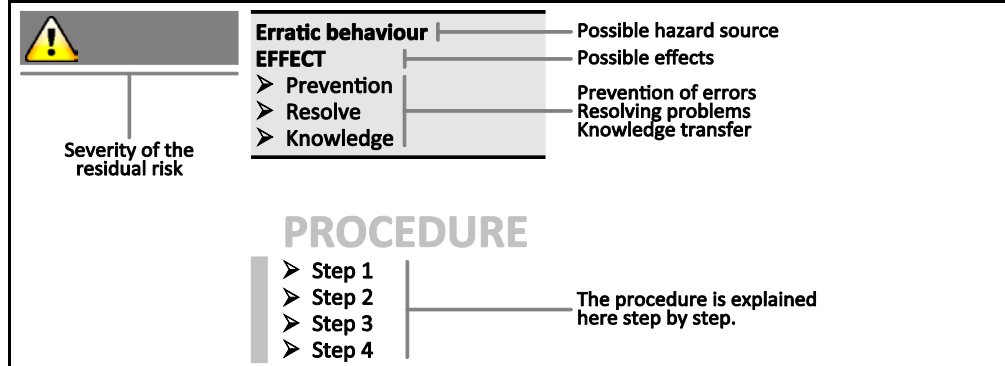

Safety information and procedure



The safety information in the installation guide is designed to protect the responsible body, operator and the equipment from damage. First inform yourself about any residual risks due to misuse before you start an operation.

1.1.2 Representation of safety identifiers

The following pictograms are used as safety identifiers. The table gives an overview of the safety identifier used here.

Identifier	Description
Mandatory sign	
	- Observe the instructions
Warning sign	
	- General warning sign - observe the instructions
	- Warning of electrical voltage
	- Warning of hot surface
	- Warning of flammable substances

1.1.3 Safety during commissioning

The following chapters are only relevant for accessories in conjunction with a Huber temperature control unit of the Unistat series and apply in addition to the operation manual of the temperature control unit used. If you have any questions regarding the installation guide, please contact our Customer Support (see page 28 in section »Contact data«). This installation guide must be kept for future use.

1.1.4 Extension of specified normal operation

The accessory is suitable for calibrating metering and control sensors when properly installed on the Huber temperature control unit. The accessory itself can **not** be used for calibrating metering and control sensors without being connected to the temperature control unit. In all other respects, the intended use as described in the operation manual of the Huber temperature control unit applies.

1.2 Responsible bodies and operators – Obligations and requirements

1.2.1 Obligations of the responsible body

Store the installation guide near the accessory where it is easy to access. Only adequately qualified operators (e.g. machine operators, chemists, chemical technical assistants, physicist etc.) may work with the accessory. Operators must be trained before handling the accessory. Verify that the operators have read and understood the installation guide. Define precise responsibilities for the operators. Personal protective equipment must be provided to the operators.

- The operating company must install a condensation water / thermal fluid drip tray below the temperature control unit (including accessory).
- The operating company must check whether national regulations require the mandatory installation of a drain tray for the installation area of the temperature control unit (incl. accessory)/the complete system.
- Our temperature control unit (incl. accessory) complies with all applicable safety standards.
- Your system which uses our temperature control unit (incl. accessory) must be just as safe.
- The operating company must design the system to ensure it is safe.
- Huber is not responsible for the safety of your system. The operating company is responsible for the safety of the system.
- Although the temperature control unit provided by Huber (incl. accessory) meets all the applicable safety standards, integration into another system may give rise to hazards that are induced by the other system's design and beyond the control of Huber.
- It is the responsibility of the system integrator to ensure that the overall system, into which this temperature control unit (incl. accessory) is integrated, is safe.
- The **>Mains isolator<** [36] on the temperature control unit (if present) can be locked in the off position to facilitate safe system installation and maintenance of the temperature control unit (incl. accessory). Accessories with their own power supply must be **additionally** disconnected from the mains connection! It is the responsibility of the operating company to develop lock-out/tag-out procedures in accordance with local regulations (e.g. CFR 1910.147 for USA).
- Only valid for water-cooled temperature control units: The operating company must ensure that the cooling water supply and drain pipes are laid frost-protected. The cooling water temperature must not fall below 3 °C. The cooling water supply must be heated if the ambient temperature is below 3 °C.

1.2.1.1 Proper disposal of resources and consumables

Do comply with all national disposal regulations applicable for you. Contact your local waste management company for any questions concerning disposal.

Overview	Material / Aids	Disposal / Cleaning
	Packing material	Keep the packaging material for future use (e.g. transport).
	Thermal fluid	Please refer to the safety data sheet of the thermal fluid used for information on its proper disposal. Use the original thermal fluid container when disposing it.
	Filling accessories, e.g. beaker	Clean the filling accessories for reuse. Make sure that the materials and cleaning agents used are properly disposed of.
	Aids such as towels, cleaning cloths	Tools used to take up spilled thermal fluid must be disposed of in the same fashion as the thermal fluid itself. Tools used for cleaning must be disposed of depending on the cleaning agent used.
	Cleaning agents such as stainless steel cleaning agents, sensitive-fabrics detergents	Please refer to the safety data sheet of the cleaning agent used for information on its proper disposal. Use the original containers when disposing of large quantities of cleaning agents.
	Consumables such as air filter mats, temperature control hoses	Please refer to the safety data sheet of the consumables used for information on their proper disposal.

1.2.2 Requirements for operators

Work on the temperature control unit / accessory is reserved for appropriately qualified specialists, who have been assigned and trained by the responsible body to do so. Operators must be at least 18 years old. Persons under the age of 18 years may operate the temperature control unit / accessory only under the supervision of a qualified specialist. The operator is responsible for other people within the unit's working range.

1.2.3 Obligations of the operators

Carefully read the installation guide before handling the temperature control unit / accessory. Always observe the safety instructions. Wear appropriate personal protective equipment (e.g. safety goggles, protective gloves, non-slip shoes) when operating the temperature control unit / accessory.

1.3 General information

1.3.1 Description of workstation

The workstation is located in front of the accessory. The workstation is determined by the peripherals connected by the customer. It is the operating company's responsibility to design it safely. The workstation design also depends on the applicable requirements of the German occupational health and safety regulations [BetrSichV] and the risk assessment for the workstation.

2 Commissioning

2.1 In-plant transport



Accessories are not transported / moved according to the specifications in this installation guide

INJURIES DUE TO CRUSHING

- Always transport / move accessories according to the specifications in this installation guide.
- Wear personal protective equipment during transport.

- If available, use the eyes on the top side of the accessory for transportation.
- Use an industrial truck for transport.
- The casters (if present) on the temperature control unit are not suitable for transport. The casters are each symmetrically loaded with 25% of the total mass of the accessory.
- Remove the packaging material (e.g. the pallet) only at the place of installation.
- Protect the accessory against transport damage.
- Do not transport the accessory alone and without aids.
- Check the load bearing capacity of the transportation route and the place of installation.
- The parking brakes must be activated at the casters (if any) and/or the leveling feet (if any) must be unscrewed/activated before the accessory is put into operation (see on page 17 the section »Unscrewing/activating the leveling feet (if any)«).

2.1.1 Lifting and transporting the accessories

2.1.1.1 Accessories with lifting eyes



The accessories are lifted at the lifting eyes without load handling equipment

DAMAGE TO THE ACCESSORIES

- Always use load handling equipment when lifting and transporting the accessories.
- The lifting eyes are only designed for a load **without** inclination (0°).
- The load handling attachment used must be adequately dimensioned. Take the dimensions and weight of the temperature control unit into account.

- Never lift and transport the accessories on the lifting eyes alone and without aids.
- Lift and transport the accessories at the lifting eyes only with a crane or an industrial truck.
- The lifting force of the crane or industrial truck must correspond at least to the weight of the accessories. See the data sheet (from page 29 in section »Annex«).

2.1.1.2 Accessories without lifting eyes

- Do not lift and transport the accessory alone and without aids.
- Lift and transport the accessory only with an industrial truck.
- The industrial truck must have a lifting force equal to or greater than the weight of the accessory. See the data sheet (from page 29 in Section »Annex«) for the weight of the accessory.

2.2 Unpacking

PROCEDURE

- Check for damage to the packaging. Damage can indicate property damage to the accessory.
- Check for any transport damage when unpacking the accessory.
- Always contact your forwarding agent regarding the settlement of claims.
- Follow the instructions on page 12, section »Proper disposal of resources and consumables« for the disposal of packaging material.

2.3 Ambient conditions

CAUTION

Unsuitable ambient conditions/unsuitable installation
SERIOUS INJURY DUE TO CRUSHING
 > Comply with the requirements under sections »Ambient conditions« and »Installation conditions«.

INFORMATION

Make sure there is adequate fresh air available at the site for the accessory. The warm exhaust air must be able to escape upwards unhindered.

Use of the accessory is permitted only under normal ambient conditions in accordance with DIN EN 61010-1:2011:

- Use only indoors. The illuminance must be at least 300 lx.
- Installation elevation up to 2000 meters above sea level.
- Maintain wall and ceiling clearance for adequate air exchange (dissipation of waste heat, supply of fresh air for the accessory and work area). Do not operate the accessory from within the cardboard box or with an inadequately dimensioned bath as this inhibits the air exchange.
- Ambient temperature values are provided on the technical data sheet; to ensure trouble-free operation, compliance with the ambient conditions is mandatory.
- Relative humidity max. 80% up to 32 °C and up to 40 °C decreasing linearly to 50%.
- Short distance to supply connections.
- The accessory must not be installed so as to hinder or even prevent access to the disconnecting device (to the power supply).

Wall clearance

Clearance in cm	
Side	
[A1] Top	free standing
[B] Left	min. 20
[C] Right	min. 20
[D] Front	min. 20
[E] Rear	min. 20
Clearance in cm (for operation in a bath)	
Side	
[A1] Top	free standing
[B] Left	min. 20
[C] Right	min. 20
[D] Front	min. 20
[E] Rear	min. 20

2.4 Installation conditions



WARNING

The accessory is placed onto the power cable of the temperature control unit
DEATH FROM ELECTRICAL SHOCK BY DAMAGE TO THE POWER CABLE

- Do not put the accessory on the power cable of the temperature control unit.

Aligning the accessory

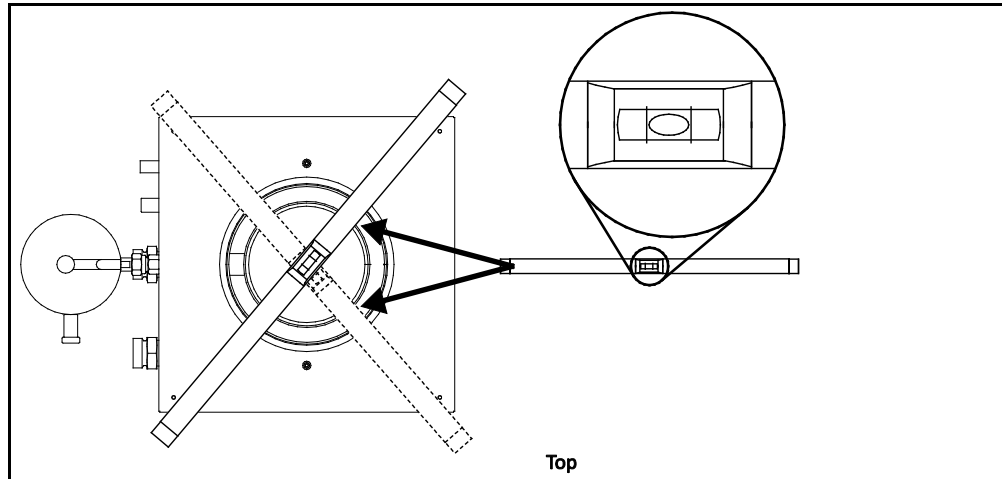

- Allow the accessory to acclimate for about 2 hours when changing from a cold to a warm environment (or vice versa). Do not turn on the accessory prior to that!
- Install upright, stable and tilt-proof.
- The accessory **must be aligned horizontally**.
- Use a non-combustible, sealed foundation.
- Keep the environment clean: Prevent slip and trip hazards.
- Wheels, if installed, must be locked after installation!
- Spilled or leaked thermal fluid must be disposed of immediately and properly. Follow the instructions for the disposal of thermal fluid and auxiliary material on page 12 the section »**Proper disposal of resources and consumables**«.
- Observe the floor load bearing capacity for large units.
- Observe the ambient conditions.

2.5 Recommended temperature control hoses



CAUTION

Use of unsuitable/defective hoses and/or hose connections

INJURIES

- Use appropriate hoses and/or hose connections.
- Check periodically for leaks and the quality of the hose and hose connections and take suitable measures (replace) as required.
- Isolate and protect temperature control hoses against contact/mechanical load.



CAUTION

Hot or cold thermal fluid and surfaces

BURNS TO LIMBS

- Avoid direct contact with the thermal fluids or the surfaces.
- Wear your personnel protective equipment (e.g. temperature-resistant safety gloves, safety goggles, safety footwear).

To connect applications, use only temperature control hoses that are compatible with the thermal fluid used. When selecting temperature control hoses, also pay attention to the temperature range in which the hoses are to be used.

- We recommend you use only temperature-insulated temperature control hoses with your accessory. The user is responsible for the insulation of connection valves.

2.6 Wrench sizes and torques

Observe the proper wrench sizes for the thermal fluid connection at the accessory. The following table lists the thermal fluid connections and the resulting wrench sizes, as well as the torque values. Always perform a leak test afterwards and re-tighten the connections if required. The values of the maximum torque (see table) must **not** be exceeded.

Connection	Sleeve nut wrench size	Connector wrench size	Recommended torques in Nm	Maximum torques in Nm
M16x1	19	17	20	24
M24x1.5	27	27	47	56
M30x1.5	36	32	79	93
	36	36	79	93
M38x1.5	46	46	130	153
G-thread (flat-sealing)	Adapt the torque to the material of the flat seal used. First hand-tighten the temperature control hose. When using adapters, do not overtighten the G-thread on the pump connection when connecting a temperature control hose. When connecting a temperature control hose to the adapter piece, secure the G thread against overwinding.			

Overview
wrench sizes and
torques

2.7 Preparations for operation

2.7.1 Unscrewing/activating the leveling feet (if any)



WARNING

**The leveling feet are not unscrewed/activated before operating the accessory
DEATH OR SERIOUS INJURY DUE TO CRUSHING**

- The parking brakes must be activated at the casters (if any) and/or the leveling feet must be unscrewed/activated before the accessory is put into operation.
- The accessory may move if the parking brakes of the casters (if any) are not activated and/or the leveling feet are not unscrewed/activated.

Ensure that the leveling feet are unscrewed/activated before you operate the accessories. Uneven floors can be compensated for by adjusting these leveling feet.

PROCEDURE

- Verify that the parking brakes of the casters (if any) have been activated.
- Unscrew the leveling feet.
- Compensate uneven floors by adjusting the leveling feet, if necessary. Use a spirit level to horizontally align the accessory.
- Tighten the lock screws on the leveling feet after aligning the accessory. This prevents the leveling feet from changing their height during operation.

2.7.2 Checking the knurled screws

PROCEDURE

- Check whether the knurled screws have been mounted and tightened:
>Drain< [8]
>Emptying of residues< [10].

2.7.3 Installing collecting container

CAUTION

Hot or cold thermal fluid and surfaces

BURNS TO LIMBS

- Avoid direct contact with the thermal fluids or the surfaces.
- Wear your personnel protective equipment (e.g. temperature-resistant safety gloves, safety goggles, safety footwear).

INFORMATION

Condensation on the bath cover, or excessive circulation in the accessory, causes thermal fluid to exit at the connection **>Spilled fluid < [74]**. This thermal fluid must be collected in a controlled manner. Please note on page 12 the section **»Proper disposal of resources and consumables«**.

INFORMATION

Only use suitable hoses and containers. Hoses / containers used must be compatible with the thermal fluid and the temperature.

PROCEDURE

- Mount a hose at the connection **>Spilled fluid < [74]**.
- Place the other end of the hose in a suitable container. The container must be compatible with the thermal fluid and the temperature.

2.8 Connecting the accessory to the temperature control unit

INFORMATION

The accessory must be connected to your temperature control unit as an **externally open** application. Follow the operation manual of the temperature control unit when connecting the accessory. Avoid bending the temperature control hoses. Use suitable angle pieces and lay the hose connections with a large radius. The minimum bending radius can be referenced in the data sheet of the temperature control hoses used.

PROCEDURE

- Remove the plastic protective caps on your accessory from the connections **>Circulation flow < [1]** and **>Circulation return < [2]**.
- Remove the plastic protective caps on your temperature control unit from the connections **>Circulation flow < [1]** and **>Circulation return < [2]**.
- Use a temperature control hose to connect the **>Circulation flow < [1]** on the accessory with the **>Circulation return < [2]** on the temperature control unit.
- Use a temperature control hose to connect the **>Circulation flow < [2]** on the accessory with the **>Circulation return < [1]** on the temperature control unit.

3 Function description

3.1 Function description of the accessory

3.1.1 General functions

The **accessory** can only be used in combination with a **temperature control unit** of the Unistat series. The accessory is connected to the temperature control unit as an externally **open** system.

The temperature is set at the connected **temperature control unit**.

3.2 To be noted when planning the test

INFORMATION

Also observe page 11, section »**Extension of specified normal operation**«.

The focus is on your application. Bear in mind that system performance is influenced by heat transfer, temperature, thermal fluid viscosity, volume flow, and flow speed.

- The place of installation of the accessory should be selected so as to ensure adequate fresh air.
- Cross-section reduction or shut-off in the thermal fluid circuit must be avoided.
- The temperature and the dynamics of the process are determined by the flow temperature. A differential temperature (Delta T) forms between flow temperature and process temperature. This temperature difference may have to be limited, because Delta T might exceed permissible application limits. Adjust the Delta T value to your application.
- Select the thermal fluid to be used in such a way that it not only permits the minimum and maximum working temperature but is also suitable with regard to combustion point, boiling point, and viscosity. In addition, the thermal fluid must be compatible with all the materials in your system.
- Avoid bending the temperature control and cooling water hoses (if required). Use suitable angle pieces and lay the hose connections with a large radius. The minimum bending radius can be referenced in the data sheet of the temperature control hoses used.
- The selected hose connections must be able to withstand the thermal fluid, the working temperatures and the admissible maximum pressure.
- Check the hoses at regular intervals for any material fatigue (e.g. cracks, leaks).
- Keep the temperature control hoses as short as possible
 - The inside diameters of the temperature control hoses must correspond at least to the pump connections. Select larger inside diameters for longer line lengths to compensate for pressure loss in the piping.
 - The viscosity of the thermal fluid determines the pressure drop and influences the temperature control result, especially at low working temperatures.
 - Too small connectors, couplers and valves can generate significant flow resistance. Your accessory will therefore be slower to reach its design temperature.
- Basically, you should only use the thermal fluids recommended by the manufacturer and only within the usable temperature and pressure range.
- The accessory should be located roughly at the same height or below the temperature control unit if the temperature is controlled close to the boiling temperature of the thermal fluid.
- Fill the accessory slowly, carefully and steadily. Wear the necessary personal protective equipment, such as goggles, heat-proof and chemical-resistant gloves, etc.
- The temperature control circuit must be vented after filling and setting all required parameters. This is required to ensure trouble-free operation of the temperature control unit and hence your accessory.

4 Setup mode

4.1 Setup mode

CAUTION

Moving the accessory during operation

SERIOUS BURNS/FREEZING OF THE HOUSING PARTS/ESCAPING THERMOFLUID

- Do not move the accessory when in operation.

NOTE

When the temperature control unit is switched off, the thermal fluid temperature in the accessory is above/below room temperature

DAMAGE TO THE ACCESSORY

- Use the temperature control unit to temper the thermal fluid in the accessory to room temperature (20 °C).
- Do not close the shut-off valves in the thermal fluid circuit.

4.1.1 Setting the setpoint

PROCEDURE

- Set the setpoint at the temperature control unit. For more information, please refer to the operation manual of the temperature control unit.

4.2 Filling and draining the accessory

The illustration "connection diagram" can be found on page 29 in section »Annex«.

CAUTION

Extremely hot / cold surfaces, connections and thermal fluids

BURNS/FREEZING OF LIMBS

- Surfaces, connections and tempered thermal fluids can be extremely hot or cold depending on the operating mode.
- Avoid direct contact with surfaces, connections and thermal fluids!
- Wear your personnel protective equipment (e.g. temperature-resistant safety gloves, safety goggles).

CAUTION

Non-compliance with the safety data sheet for the thermal fluid to be used

INJURIES

- Risk of injury to the eyes, skin, respiratory tract.
- The safety data sheet for the thermal fluid to be used must be read prior to using it and its content must be respected.
- Observe the local regulations/work instructions.
- Wear your personal protective equipment (e.g. temperature-resistant safety gloves, safety goggles, safety footwear).
- Danger of slipping because floor and work area are contaminated. Clean the work station and follow the instructions for the disposal of thermal fluid and material on page 12 in Section »Proper disposal of resources and consumables«.

CAUTION

Hot or very cold thermal fluid

SERIOUS BURNS/FREEZING OF LIMBS

- Before draining, ensure that the thermal fluid has room temperature (20 °C).
- If, at this temperature, the thermal fluid is too viscous to be drained: Control the temperature of the thermal fluid for a few minutes until the viscosity will allow drainage. Never control the temperature of the thermal fluid when the Drain is open.
- Danger of burns when draining thermal fluids at temperatures above 20 °C.
- Wear your personal protective equipment when carrying out the drain operation.
- Only drain with a suitable draining hose and container. These must be resistant to the thermal fluid and the temperature.

4.2.1 Filling the accessory

Thermal fluid level

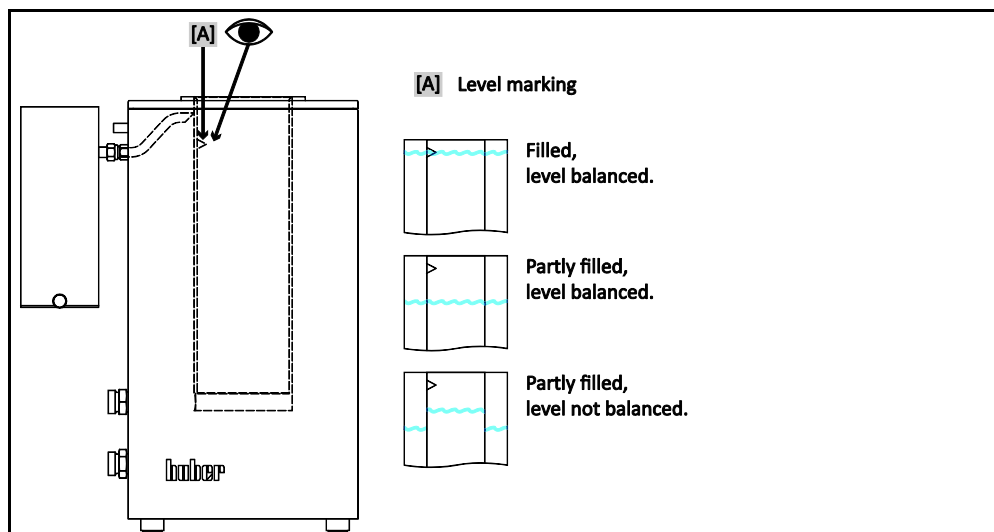
**INFORMATION**

The volume expansion of the thermal fluid changes depending on the operating temperature range in which you wish to work. The bath level may not drop below the minimum when working at the “lowest” working temperature and there must be no overflow from the **>Overflow vessel< [75]** when working at the “highest” working temperature. Drain any excessive amount of thermal fluid from the **>Overflow vessel< [75]** (see on page 22 the section **»Draining the overflow vessel«**) into a suitable container. Check if the thermal fluid can be reused. Please note on page 12 the section **»Proper disposal of resources and consumables«**.

- During the fill process, ensure any necessary measures, such as earthing the tanks, funnels and other aids, have been taken.
- Fill to the lowest possible height.

PROCEDURE

- Remove the bath cover from the accessory.
- Fill the calibration bath as described in the operation manual of the temperature control unit in the section **»Externally open application«**. The **>Fill level mark< [A]** indicates the fill level in the accessory.
- Wait 10 minutes until the level in the accessory has settled.
- Refill thermal fluid via the temperature control unit as needed.
- Fit the bath cover on the accessory. The accessory is filled.

4.2.2 Draining the accessory

PROCEDURE

- Drain the temperature control unit and the accessory as described in the operation manual of the temperature control unit.

PROCEDURE

Removal of residual liquid

- Keep a suitable container (it must be compatible with the thermal fluid and the temperature) ready for collecting the thermal fluid.
- Open the knurled screw at the **>Drain<** [8] of the accessory.
The thermal fluid of the accessory will flow into the container as soon as you have opened the knurled screw. Check if the thermal fluid can be reused. Please note on page 12 the section **»Proper disposal of resources and consumables«**.
- Wait until the accessory is empty.
- Leave the accessory open for a while to allow it to dry out and the residue to drain (without knurled screw and without bath cover).
- Re-fit the knurled screw to the **>Drain<** [8].
- The accessory and the temperature control unit are now drained.

4.2.3 Draining the overflow vessel

INFORMATION

Controlling the temperature of the thermal fluid filled may expand the thermal fluid and excessive thermal fluid will be collected by the **>Overflow vessel<** [75]. The **>Overflow vessel<** [75] must be regularly monitored or checked during operation. The thermal fluid must not overflow from the **>Overflow vessel<** [75]. Excessive thermal fluid must be drained by means of the **>Emptying of residues<** [10] if necessary. Check if the thermal fluid can be reused. Please note on page 12 the section **»Proper disposal of resources and consumables«**.

PROCEDURE

- Keep a suitable container (it must be compatible with the thermal fluid and the temperature) ready for collecting the thermal fluid.
- On the **>Overflow vessel<** [75], open the knurled screw at **>Emptying of residues<** [10].
The thermal fluid will flow from the **>Overflow vessel<** [75] into the container as soon as you have opened the knurled screw. Check if the thermal fluid can be reused. Please note on page 12 the section **»Proper disposal of resources and consumables«**.
- Wait until the **>Overflow vessel<** [75] is empty.
- On the **>Overflow vessel<** [75] re-fit the knurled screw at **>Emptying of residues<** [10]. The **>Overflow vessel<** [75] is now drained.

5 Normal operation

5.1 Automatic operation



Extremely hot / cold surfaces, connections and thermal fluids

BURNS/FREEZING OF LIMBS

- Surfaces, connections and tempered thermal fluids can be extremely hot or cold depending on the operating mode.
- Avoid direct contact with surfaces, connections and thermal fluids!
- Wear your personnel protective equipment (e.g. temperature-resistant safety gloves, safety goggles).

5.1.1 Temperature control

5.1.1.1 Starting the temperature control process

Prerequisite: The temperature control unit and the accessory are filled and vented.

PROCEDURE

- Start the temperature control process as described in the operation manual of the temperature control unit.
- Regularly check the fill level of the »**Overflow vessel**« [75] at the accessory. Drain thermal fluid as described on page 22 in section »**Draining the overflow vessel**« as required.

5.1.1.2 Ending the temperature control process



When the temperature control unit is switched off, the thermal fluid temperature in the accessory is above/below room temperature

DAMAGE TO THE ACCESSORY

- Use the temperature control unit to temper the thermal fluid in the accessory to room temperature (20 °C).
- Do not close the shut-off valves in the thermal fluid circuit.

The temperature control process can be ended at any time.

PROCEDURE

- Stop the temperature control process as described in the operation manual of the temperature control unit.

6 Service/maintenance

6.1 Maintenance

NOTE

Carrying out maintenance work not described in this installation guide

DAMAGE TO THE ACCESSORY

- For maintenance work not described in the installation guide, contact Huber company.
- Maintenance work not described in this installation guide is reserved for qualified specialists trained by Huber.
- Only perform the following maintenance work on the accessory yourself.

6.1.1 Function check and visual inspection

Inspection intervals

Cooling*	Description	Maintenance interval	Comment	Person responsible
A/W	Visually inspect hoses and hose connections	Prior to switching on the temperature control unit	Exchange leaking hoses and hose connections prior to switching on the temperature control unit. Please see on page 24 the section » Replacing temperature control hoses «.	Operating company and/or operators
A/W	Thermal fluid inspection	As required	–	Operating company and/or operators
A/W	Check the fill level of the collecting container at the connection » Spilled fluid « [74].	As required	Drain the collecting container as necessary. Dispose of its contents properly. Please see on page 25 the section » Drain the collecting container «.	Operating company and/or operators
A/W	Check the fill level of the » Overflow vessel « [75]	As required	Drain the » Overflow vessel « [75] as necessary. Check if the thermal fluid can be reused. Please note on page 12 the section » Proper disposal of resources and consumables «.	Operating company and/or operators
A/W	Inspect the accessory for damage and stability	Every 12 months or after a change of location	–	Operating company and/or operators

*A = Air cooling; W = Water cooling

6.1.2 Replacing temperature control hoses

Replace defective temperature control hoses **before** you switch on the temperature control unit / accessories.

PROCEDURE

- Exchange the thermal fluid hoses as described in the operation manual of the temperature control unit.

6.1.3 Drain the collecting container

PROCEDURE

- To empty the full collecting container, have an empty collecting container ready. The container must be compatible with the thermal fluid and the temperature.
- Pull the end of the hose out of the full collecting container and insert it into the empty collecting container.
- Empty the full collecting container and dispose of its contents properly. The collected thermal fluid must not be reused. Please note on page 12 the section »**Proper disposal of resources and consumables**«.
- Keep the empty container for later use or dispose of it properly. Please note on page 12 the section »**Proper disposal of resources and consumables**«.

6.2 Thermal fluid inspection, replacement and circuit cleaning

Check and change the thermal fluid and clean the thermal fluid circuit as described in the operation manual of the temperature control unit.

6.3 Cleaning the surfaces



Extremely hot / cold surfaces, connections and thermal fluids

BURNS/FREEZING OF LIMBS

- Surfaces, connections and tempered thermal fluids can be extremely hot or cold depending on the operating mode.
- Avoid direct contact with surfaces, connections and thermal fluids!
- Wear your personnel protective equipment (e.g. temperature-resistant safety gloves, safety goggles).

A standard stainless steel cleaning agent is suitable for cleaning the stainless steel surfaces. Carefully clean painted surfaces (damp only) using a solution of sensitive-fabrics detergent. Follow the instructions on page 12, section »**Proper disposal of resources and consumables**« for the disposal of cleaning agents and material.

6.4 Decontamination/repairs



Returning an accessory for repair that was not decontaminated

PHYSICAL INJURY AND PROPERTY DAMAGE CAUSED BY HAZARDOUS MATERIALS IN OR ON THE ACCESSORY

- Carry out appropriate decontamination.
- The decontamination process depends on the type and quantity of the materials used.
- Consult the relevant safety data sheet.
- You will find a prepared return receipt at www.huber-online.com.

As the responsible body you are responsible for carrying out decontamination **before** third-party personnel come into contact with the temperature control unit / accessory. Decontamination must be carried out **before** the temperature control unit / accessory is returned for repair or inspection. Attach a clearly visible written notice stating that the temperature control unit / accessory has been decontaminated.

To simplify the process, we have prepared a form for you. This is available for download at www.huber-online.com.

7 Shutting down

7.1 Safety instructions and basic principles



WARNING

Risk of tipping due to unstable accessory

SERIOUS INJURY AND PROPERTY DAMAGE

- Avoid risk of tipping due to unstable accessory.



CAUTION

Non-compliance with the safety data sheet for the thermal fluid to be used

INJURIES

- Risk of injury to the eyes, skin, respiratory tract.
- The safety data sheet for the thermal fluid to be used must be read prior to using it and its content must be respected.
- Observe the local regulations/work instructions.
- Wear your personal protective equipment (e.g. temperature-resistant safety gloves, safety goggles, safety footwear).
- Danger of slipping because floor and work area are contaminated. Clean the work station and follow the instructions for the disposal of thermal fluid and material on page 12 in Section »Proper disposal of resources and consumables«.



CAUTION

Hot or very cold thermal fluid

SERIOUS BURNS/FREEZING OF LIMBS

- Before draining, ensure that the thermal fluid has room temperature (20 °C).
- If, at this temperature, the thermal fluid is too viscous to be drained: Control the temperature of the thermal fluid for a few minutes until the viscosity will allow drainage. Never control the temperature of the thermal fluid when the Drain is open.
- Danger of burns when draining thermal fluids at temperatures above 20 °C.
- Wear your personal protective equipment when carrying out the drain operation.
- Only drain with a suitable draining hose and container. These must be resistant to the thermal fluid and the temperature.

INFORMATION

All safety instructions are important and must be followed during working operations according to the installation guide!

7.2 Switch-off

PROCEDURE

- Switch off the temperature control unit as described in the operation manual of the temperature control unit.

7.3 Draining the accessory

PROCEDURE

- Drain the accessory as described on page 22 in section »Draining the accessory«.
- Drain the >Overflow vessel< [75] as described on page 22 in section »Draining the overflow vessel«.
- Check if the thermal fluid can be reused. Please note on page 12 the section »Proper disposal of resources and consumables«.

7.4 Dismantling the collecting container

PROCEDURE

- Drain the collecting container as described on page 25 in section »**Drain the collecting container**«. Please note on page 12 the section »**Proper disposal of resources and consumables**«.
- Remove the hose from the accessory connection >Spilled fluid< [74]. Please note on page 12 the section »**Proper disposal of resources and consumables**«.

7.5 Separating the accessory from the temperature control unit

PROCEDURE

- Drain the temperature control unit and the accessory **before** separating them.
- Remove the temperature control hose from the >Circulation return< [2] on the accessory and from the >Circulation flow< [1] on the temperature control unit.
- Remove the temperature control hose from the >Circulation flow< [1] on the accessory and from the >Circulation return< [2] on the temperature control unit.
- Mount the protective plastic caps onto the accessory connections >Circulation flow< [1] and >Circulation return< [2].
- Mount the protective plastic caps onto the temperature control unit connections >Circulation flow< [1] and >Circulation return< [2].

7.6 Packing

Use the original packaging wherever possible! Further information can be found on page 14 in section »Unpacking«.

7.7 Shipping

NOTE

Improper transportation of accessories

MATERIAL DAMAGE

- Do not transport the unit in a truck when the unit rests on its casters or leveling feet.
- Comply with all requirements in this section to avoid damage to the accessories.

Pallet with squared timber for free-standing units

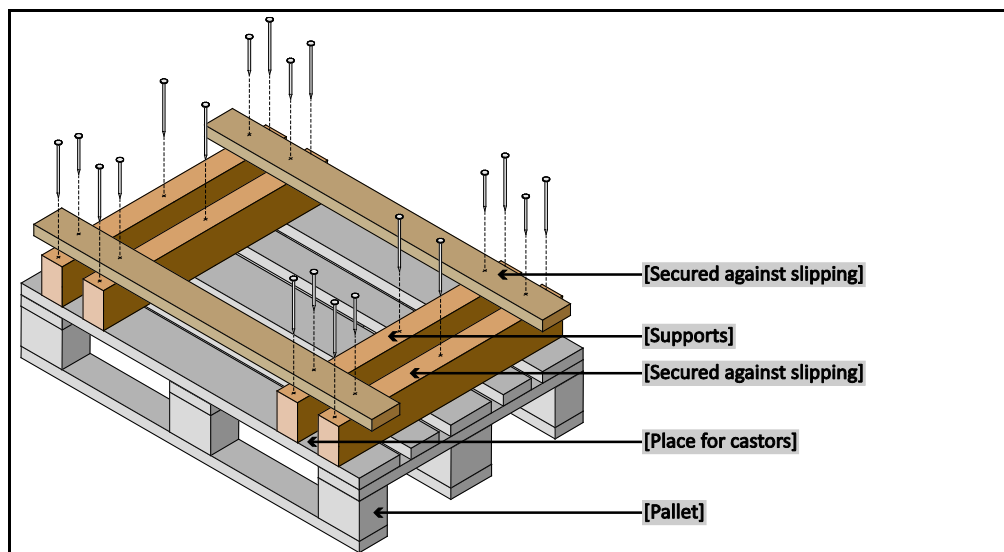

If fitted, use the lugs located on the top of the accessory for transportation. Do not transport the accessory alone and without aids.

- Always use the original packaging for transport.
- Always transport the accessory upright on a pallet!
- Protect attachments from damage during transport!
- During transport, place the accessory on squared timber to protect the casters/feet.
- Secure with tensioning belts/lashing straps rated for the weight concerned.
- Additionally secure (depending on model) with plastic film, cardboard and straps.

7.8 Disposal

NOTE

Improper disposal

ENVIRONMENTAL DAMAGE

- Spilled or leaked thermal fluid must be disposed of immediately and properly. Follow the instructions for the disposal of thermal fluid and auxiliary material on page 12 in section »**Proper disposal of resources and consumables**«.

Huber temperature control units and Huber accessories are made of high quality, recyclable materials. For example: Stainless steel 1.4301 / 1.4401 (V2A), copper, nickel, FKM, Perbunan, NBR, ceramic, carbon, Al-Oxid, red brass, brass, nickel-plated brass and silver solder. Proper recycling of the temperature control unit and accessories can actively help reduce CO₂ emissions in the production of these materials. Follow the laws and regulations of your jurisdiction when disposing material.

7.9 Contact data

INFORMATION

Please contact your supplier and/or local dealer **before** you return your accessories. The contact information can be found "Contact" on our home page www.huber-online.com. Please have the serial number of the accessories ready. The serial number can be found on the nameplate of the accessories.

7.9.1 Telephone number: Customer Support

If your country is not mentioned in the list below: The responsible service partner can be found on our homepage www.huber-online.com under the heading „Contact“.

- Huber Deutschland: +49 781 9603 244
- Huber China: +86 (20) 89001381
- Huber India: +91 80 2364 7966
- Huber Ireland: +44 1773 82 3369
- Huber Italia: +39 0331 181493
- Huber Swiss: +41 (0) 41 854 10 10
- Huber UK: +44 1773 82 3369
- Huber USA: +1 800 726 4877 | +1 919 674 4266

7.9.2 Telephone number: Sales

Telephone: +49-781-9603-123

7.9.3 Email address: Customer Support

Email: support@huber-online.com

7.10 Certificate of Compliance

Please read page 25, section »**Decontamination/repairs**«.

8 Annex

Inspired by **temperature** designed for you

Peter Huber Kältemaschinenbau SE
Werner-von-Siemens-Str. 1
77656 Offenburg / Germany

Telefon +49 (0)781 9603-0
Telefax +49 (0)781 57211

info@huber-online.com
www.huber-online.com

Technischer Service: +49 (0)781 9603-244

-125 °C ... +425 °C

huber