



# Inspired by temperature

Betriebsanleitung · Operation manual · Manual de instrucciones · Manuel d'utilisation · Manuale de d'uso · 사용 설명서 · Manual de instruções · Инструкция по эксплуатации · Kullanım talimatı · 操作说明书

## Multi Flow Control Cube

Betriebsanweisung · Manual de instrucciones · 사용 설명서 · Инструкция по эксплуатации · Kullanım talimatı · 操作说明书 · Betriebsanweisung · Manual de instrucciones · 사용 설명서 · Инструкция по эксплуатации · Kullanım talimatı · 操作说明书

**This documentation does not contain a device-specific technical appendix.**

You can request the full operating instructions from [info@huber-online.com](mailto:info@huber-online.com). Please give the model designation and serial number of your temperature control unit in your e-mail.

**huber**





OPERATION MANUAL

**Multi  
Flow Control Cube**



# Multi Flow Control Cube

## Pilot ONE®

This operation manual is a translation of the original operation manual.

### VALID IN CONJUNCTION WITH:

HUBER temperature control units  
with Pilot ONE®  
in conjunction with a  
process control system (PCS)

„Pilot ONE“

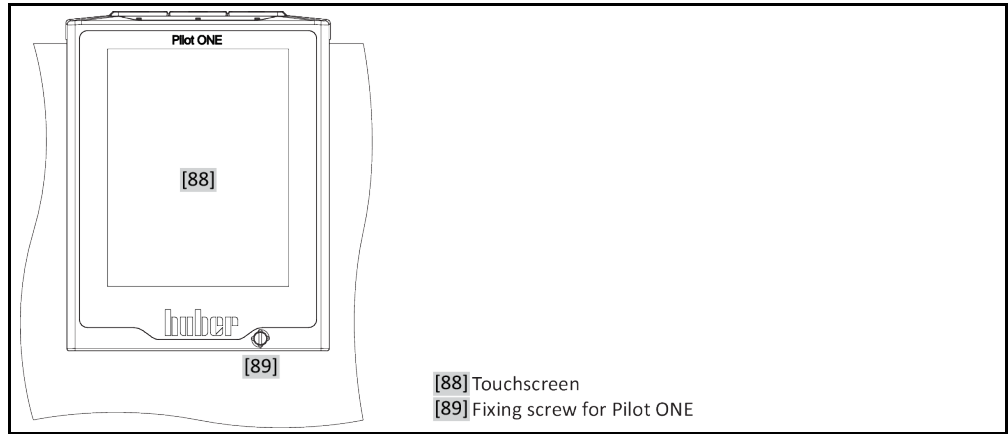

- [88] Touchscreen
- [89] Fixing screw for Pilot ONE

Layout of the "Home" screen

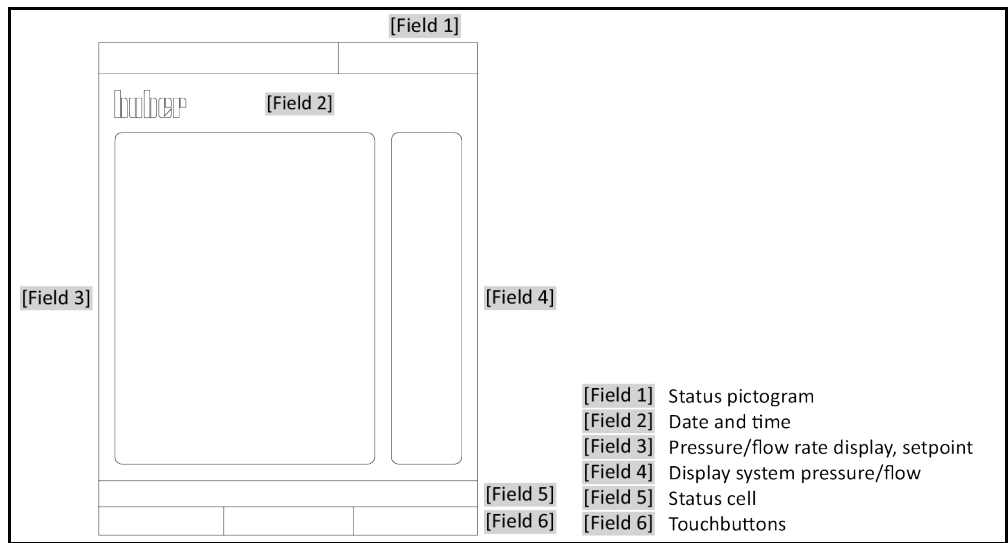

- [Field 1] Status pictogram
- [Field 2] Date and time
- [Field 3] Pressure/flow rate display, setpoint
- [Field 4] Display system pressure/flow
- [Field 5] Status cell
- [Field 6] Touchbuttons

# Table of contents

V1.1.0en/05.05.26

<b>1</b>	<b>Introduction</b>	<b>12</b>
<b>1.1</b>	<b>Representation of textual emphases</b>	<b>12</b>
<b>1.2</b>	<b>Information on the EU Declaration of Conformity</b>	<b>12</b>
<b>1.3</b>	<b>Safety</b>	<b>12</b>
1.3.1	Symbols used for Safety Instructions	12
1.3.2	Representation of symbols on the accessory	13
1.3.3	Safety during commissioning	13
1.3.4	Extension of specified normal operation	13
1.3.5	Reasonably foreseeable misuse	14
<b>1.4</b>	<b>Obligations of the responsible body</b>	<b>15</b>
1.4.1	Proper disposal	15
<b>1.5</b>	<b>Obligations of the operators</b>	<b>16</b>
1.5.1	Requirements for operators	16
<b>1.6</b>	<b>Description of workstation</b>	<b>16</b>
<b>1.7</b>	<b>Further protective devices</b>	<b>16</b>
<b>2</b>	<b>Commissioning</b>	<b>17</b>
<b>2.1</b>	<b>In-plant transport</b>	<b>17</b>
2.1.1	Lifting and transporting the accessories	17
2.1.1.1	Accessories with lifting eyes	17
2.1.1.2	Accessories without lifting eyes	18
2.1.2	Mounting/removing leveling feet	18
2.1.3	Positioning the accessories	18
2.1.3.1	Accessories with casters	18
2.1.3.2	Accessories with casters including leveling feet	19
2.1.3.3	Accessories without casters	19
<b>2.2</b>	<b>Unpacking</b>	<b>19</b>
<b>2.3</b>	<b>Ambient conditions</b>	<b>19</b>
2.3.1	EMC-specific notes	20
<b>2.4</b>	<b>Installation conditions</b>	<b>21</b>
<b>2.5</b>	<b>Recommended temperature control hoses</b>	<b>21</b>
<b>2.6</b>	<b>Wrench sizes and torques</b>	<b>22</b>
<b>2.7</b>	<b>Preparations for operation</b>	<b>22</b>
2.7.1	Activating the leveling feet	22
2.7.2	Connecting the accessory to the temperature control unit	23
2.7.3	Connecting the accessory and the temperature control unit to the process control system	24
2.7.4	Connecting the functional ground	24
<b>2.8</b>	<b>Connecting to the power supply</b>	<b>25</b>
<b>3</b>	<b>Function description</b>	<b>26</b>
<b>3.1</b>	<b>Function description of the accessory</b>	<b>26</b>
3.1.1	General functions	26
3.1.2	Other functions	26
<b>3.2</b>	<b>Information on the heat transfer fluids</b>	<b>26</b>
<b>3.3</b>	<b>To be noted when planning the test</b>	<b>27</b>
<b>3.4</b>	<b>“Pilot ONE®” controller</b>	<b>28</b>

3.4.1	Functional overview of “Pilot ONE®” .....	28
<b>3.5</b>	<b>Clock/event function</b> .....	<b>29</b>
3.5.1	Rechargeable accumulator .....	29
<b>3.6</b>	<b>Operation via the touch screen</b> .....	<b>29</b>
<b>3.7</b>	<b>Display instruments</b> .....	<b>30</b>
3.7.1	The touchscreen [88] .....	30
<b>3.8</b>	<b>Control instruments</b> .....	<b>30</b>
3.8.1	The touchbuttons.....	30
3.8.2	The categories.....	31
3.8.3	The sub-categories.....	31
3.8.4	The dialogs .....	31
<b>3.9</b>	<b>Function examples</b> .....	<b>31</b>
3.9.1	Display of software version.....	31
3.9.2	Settings via “Category menu” .....	31
3.9.2.1	Setting the “Control mode” .....	32
3.9.2.2	Setting the “Pressure setpoint” .....	32
3.9.2.3	Setting the “Flow setpoint” .....	32
3.9.2.4	Setting the “Pressure control parameter” .....	32
3.9.2.5	Setting the “Flow control parameter” .....	32
3.9.2.6	Displaying the settings.....	32
3.9.2.7	Resetting control parameters.....	32
3.9.3	Settings via “Home screen” .....	33
3.9.3.1	Changing the “Control mode” .....	33
3.9.3.2	Changing the “Pressure setpoint” or “Flow setpoint” .....	33
<b>4</b>	<b>Setup mode</b> .....	<b>34</b>
<b>4.1</b>	<b>Setup mode</b> .....	<b>34</b>
4.1.1	Turning on the accessory .....	34
4.1.2	Switching off the accessories .....	35
<b>4.2</b>	<b>Filling and draining the accessory</b> .....	<b>35</b>
4.2.1	Filling the accessory .....	36
4.2.2	Draining the accessory .....	36
<b>5</b>	<b>Normal operation</b> .....	<b>38</b>
<b>5.1</b>	<b>Automatic operation</b> .....	<b>38</b>
5.1.1	Temperature control.....	38
5.1.1.1	Starting the temperature control process.....	38
5.1.1.2	Ending the temperature control process .....	38
<b>6</b>	<b>Interfaces and software update</b> .....	<b>39</b>
<b>6.1</b>	<b>Firmware update</b> .....	<b>39</b>
<b>6.2</b>	<b>Data communication</b> .....	<b>39</b>
6.2.1	PB commands .....	39
<b>7</b>	<b>Maintenance</b> .....	<b>41</b>
<b>7.1</b>	<b>Electrical fuse</b> .....	<b>41</b>
<b>7.2</b>	<b>Replacing the “Pilot ONE®”</b> .....	<b>41</b>
<b>7.3</b>	<b>Maintenance</b> .....	<b>41</b>
7.3.1	Function check and visual inspection .....	42
7.3.2	Replacing temperature control hoses.....	42
<b>7.4</b>	<b>Heat transfer fluid inspection, replacement and circuit cleaning</b> .....	<b>42</b>
<b>7.5</b>	<b>Cleaning the surfaces</b> .....	<b>42</b>
<b>7.6</b>	<b>Plug contacts</b> .....	<b>43</b>

<b>7.7</b>	<b>Decontamination before shipping .....</b>	<b>43</b>
<b>8</b>	<b>Shutting down .....</b>	<b>44</b>
<b>8.1</b>	<b>Safety instructions and basic principles .....</b>	<b>44</b>
<b>8.2</b>	<b>Switch-off .....</b>	<b>45</b>
<b>8.3</b>	<b>Draining the accessory .....</b>	<b>45</b>
<b>8.4</b>	<b>Separating the accessory and the temperature control unit from the process control system .....</b>	<b>45</b>
<b>8.5</b>	<b>Separating the accessory from the temperature control unit .....</b>	<b>45</b>
<b>8.6</b>	<b>Deactivating the leveling feet .....</b>	<b>46</b>
<b>8.7</b>	<b>Packing .....</b>	<b>46</b>
<b>8.8</b>	<b>Shipping.....</b>	<b>46</b>
<b>8.9</b>	<b>Disposal .....</b>	<b>47</b>
<b>8.10</b>	<b>Contact data .....</b>	<b>47</b>
8.10.1	Telephone number: Customer Support .....	47
8.10.2	Telephone number: Sales .....	47
8.10.3	Email address: Customer Support.....	47
<b>8.11</b>	<b>Clearance certificate.....</b>	<b>47</b>
<b>9</b>	<b>Annex .....</b>	<b>48</b>



## Foreword

Dear customer,

Thank you for choosing accessories from Peter Huber Kältemaschinenbau SE. You made a good choice. Thank you for your trust.

Please read this operation manual carefully before putting the unit into operation. Strictly follow all notes and safety instructions.

Follow the operation manual concerning transport, start-up, operation, maintenance, repair, storage and disposal.

We offer a full warranty for your accessory subject to proper operation.

In this operation manual, the component listed on page 5 is referred to as accessory, and Peter Huber Kältemaschinenbau SE as Huber company or Huber.

Liability for errors and misprints excluded.

The following trademarks and the Huber logo are registered trademarks of Peter Huber Kältemaschinenbau SE in Germany and/or other countries worldwide:

BFT®, CC®, Chili®, Com.G@te®, Compatible Control®, CoolNet®, DC®, E-grade®, Grande Fleur®, Huber Piccolo®, KISS®, Minichiller®, Ministat®, MP®, MPC®, Peter Huber Minichiller®, Petite Fleur®, Pilot ONE®, RotaCool®, Rotostat®, SpyControl®, SpyLight®, Tango®, TC®, UC®, Unical®, Unichiller®, Unimotive®, Unipump®, Unistat®, Unistat Tango®, Variostat®.

The following trademarks are registered in Germany to DWS Synthesetechnik:

DW-Therm®, DW-Therm HT®.

The following trademark is a registered trademark of BASF SE:

Glysantin®.

# 1 Introduction

## 1.1 Representation of textual emphases

The following emphases are used in the texts and illustrations.

Overview	Emphasis	Description
	■ ➤ Abc	Step-by-step explanation of the procedure.
	→	Reference to information or procedures.
	»Abc«	Reference to a paragraph in the document.
	>Abc< [123]	Reference to the wiring diagram in the annex, specifying the designation and search string (number).
	>Abc< [ABC]	Reference to a drawing in the same paragraph with specification of designation and search string (character).
	▪	List, first level
	–	List, second level

## 1.2 Information on the EU Declaration of Conformity





 The temperature control unit complies with the basic safety and occupational health requirements of the European guidelines listed below:

- Machinery Directive
- Low Voltage Directive
- EMC Directive

## 1.3 Safety

### 1.3.1 Symbols used for Safety Instructions

The documentation uses the following combinations of characters and signal word as safety information. The signal word describes the classification of the residual risk when the safety information is disregarded.

	Denotes an immediate hazardous situation that will result in death or serious injuries.
	Denotes a general hazardous situation that may result in death or serious injuries.
	Denotes a hazardous situation that can result in injury.
	Denotes a situation that can result in property material damage.
	Denotes important notes and usable hints.

Explanation

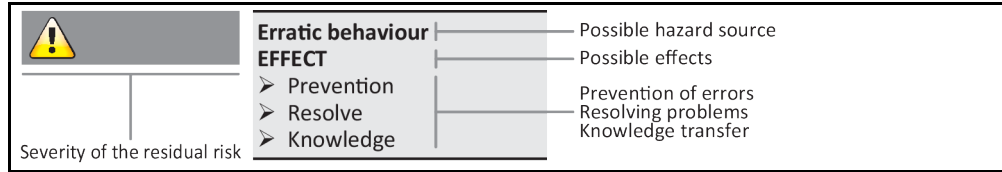

The safety information is designed to protect the operating company, the operators and the equipment from damage. Before starting the respective activity, you must inform yourself about the residual risks involved with incorrect handling.

### 1.3.2 Representation of symbols on the accessory

The following characters are used.

Overview

Sign	Description
<b>Mandatory sign</b>	
	- Observe the instructions
<b>Warning sign</b>	
	- General warning sign - Observe the instructions
	- Warning of electrical voltage
	- Warning of hot surface
	- Warning of flammable substances
<b>Miscellaneous</b>	
	Follow the national and local instructions for the disposal of electrical appliances.

### 1.3.3 Safety during commissioning

The following chapters are relevant for accessories in connection with a Huber temperature control unit, and apply in addition to the operation manual of the temperature control unit used here. If you have any questions, please contact our Customer Support. → Page 47, section »Contact data«. Keep this operation manual for future reference.

### 1.3.4 Extension of specified normal operation



**The accessories are operated in a potentially explosive area**  
**DEATH FROM EXPLOSION**  
 ➤ Do NOT install or start up the accessories within an ATEX zone.

**WARNING****Improper use****SEVERE INJURIES AND MATERIAL DAMAGE**

- Keep the operation manual easily accessible in the immediate vicinity of the temperature control unit and/or the accessories.
- Only adequately qualified operators may work with the temperature control unit and/or the accessories.
- Operators must be trained before handling the temperature control unit and/or its accessories.
- Check to ensure that the operators have read and understood the operation manual.
- Define precise responsibilities of the operators.
- Personal protective equipment must be provided to the operators.
- Be sure to follow the safety rules of the responsible body to protect life and limb and to limit damages!

**NOTE****Modifications to the accessory by third-parties****DAMAGE TO THE ACCESSORY AND THE TEMPERATURE CONTROL UNIT**

- Do not allow third parties to make technical modifications to the accessories.
- Any modification that is not approved by Huber invalidates all EU Declarations of Conformity for the accessories.
- Only specialists trained by Huber may carry out modifications, repairs or maintenance work.
- **It is imperative to observe:**
- Only use the accessories in a fault-free condition!
- Have the start-up and repairs carried out by specialists only!
- Do not ignore, bypass, dismantle or disconnect any safety devices!

**NOTE****A pressure-sensitive external application is run with the accessory without an overpressure protection device being installed****MATERIAL DAMAGE TO THE EXTERNAL APPLICATION**

- To protect a pressure-sensitive external application (such as a glass apparatus), use an overpressure protection device in the supply line.
- Do not use accessories as an isolating valve. The outputs cannot be completely closed due to the design.
- The external application can be damaged by excessive pressure if the return is locked.

Depending on the model, the accessory regulates the flow rate (with or without pressure limitation) or the pressure for an **externally closed application**. For this, the accessory must be properly installed on the temperature control unit. The accessory must be used only in combination with a Huber temperature control unit. The accessory can **not** be used without being connected to a temperature control unit. The temperature control unit and accessory **must** be controlled/monitored by a process control system. Otherwise the intended use applies as described in the operation manual of the temperature control unit. For the technical specification, refer to the datasheet. → From page 48, Section »Annex«. Install, set up and operate the accessory according to the instructions in this operation manual. Any failure to comply with the operation manual is considered as improper operation. The accessory was manufactured according to the state of the art and the recognized safety rules and regulations.

The accessory is not a safety device for the unrestricted protection of a pressure-sensitive external application (e.g. a glass apparatus). The maximum pump pressure may be applied to your external application if the accessory is defective. A sufficiently dimensioned overpressure protection device must be installed in the supply line (pressure side) to protect your external application. The installed overpressure protection device is destroyed in the event of a fault and thus protects the external application against damage. The approved temperature range is indicated on the nameplate of the accessory.

### 1.3.5 Reasonably foreseeable misuse

Use with medical devices (e.g. in Vitro diagnostic procedure) or for direct foodstuff temperature control is **NOT** permissible.

The temperature control unit / accessory **must not be used** for any purposes other than temperature control in accordance with the operation manuals.

The manufacturer accepts **NO** liability for damage caused by **technical modifications** to the temperature control unit / accessory **improper handling** or use of the temperature control unit / accessory if the operation manuals are **not observed**.

## 1.4 Obligations of the responsible body

Keep the operation manual easily accessible in the immediate vicinity of the accessories. Only adequately qualified operators (e.g. machine operators, chemists, chemical technical assistants, physicist etc.) are allowed to work with the accessories. Operators must be trained before handling the accessories. Check that the operators have read and understood the operation manual. Define precise responsibilities for the operators. Personal protective equipment must be provided to the operators.

- The responsible body must install a condensation water / heat transfer fluid drip tray below the temperature control unit (including accessories).
- The use of a drip tray may be prescribed by national legislation for the installation area of the temperature control unit (incl. accessory). The responsible body must check and apply the national regulations applicable for it accordingly.
- The temperature control unit (including accessory) complies with all applicable safety standards.
- Your system, which uses our temperature control unit (including accessory), must be equally safe.
- The responsible body must design the system to ensure it is safe.
- Huber is not responsible for the safety of your system. The responsible body is responsible for the safety of the system.
- Whilst the temperature control unit (including accessory) provided by Huber meets all the applicable safety standards, integration into a system may give rise to hazards that are characteristic of the other system's design and beyond the control of Huber.
- It is the responsibility of the system integrator to ensure that the overall system into which this temperature control unit (including accessory) is integrated is safe.
- The **>Mains isolator<** [36] on the temperature control unit/accessory can be locked in the off position to facilitate safe system installation and maintenance of the temperature control unit (including accessory). Accessories with own power supply must be **additionally** disconnected from the power grid connection! It is the responsibility of the responsible body to develop any lock-out/tag-out procedure for the energy source in accordance with local regulations (e.g. CFR 1910.147 for the US).

### 1.4.1 Proper disposal

The operating company must check and apply the national and local regulations applicable for it accordingly.

Overview	Material	Description
	Packaging material	Keep the packaging material for future use (e.g. transport).
	Heat transfer fluid	Disposal see safety data sheet of heat transfer fluid. Use original containers to dispose of larger amounts.
	Filling accessories	Clean filling accessories (such as beaker) for re-use. Auxiliary material and cleaning agents used must also be properly disposed of.
	Aids	Absorption of heat transfer fluid: The aids used (such as cloths and cleaning rags) must be disposed of according to the heat transfer fluid used. Use of cleaning agents: The aids used (such as cloths and cleaning rags) must be disposed of according to the cleaning agent used.
	Cleaning agent	Disposal see safety data sheet of cleaning agent. Use original containers to dispose of larger amounts.
	Consumables	Disposal see data sheet of consumables (such as air filter mats, temperature control hoses).
	Refrigerants	Work on the coolant circuit must be carried out by approved refrigeration/air-conditioning system contractors!

## 1.5 Obligations of the operators

Carefully read the operation manual before you handle the temperature control unit / accessories. Always observe the safety instructions. Wear appropriate personal protective equipment (e.g. safety goggles, protective gloves, non-slip shoes) when operating the temperature control unit / accessories.

### 1.5.1 Requirements for operators

Work on the temperature control unit / accessory is reserved for appropriately qualified specialists, who have been assigned and trained by the responsible body to do so. Operators must be at least 18 years old. Persons under the age of 18 years may operate the temperature control unit / accessory only under the supervision of a qualified specialist. The operators are responsible for third parties within the unit's working range.

## 1.6 Description of workstation

The workstation is located in front of the control panel of the process control system. The workstation is determined by the peripherals connected by the customer. It is the responsible body's responsibility to design it safely. The workstation design also depends on the applicable requirements of the German occupational health and safety regulations [BetrSichV] and the risk analysis for the workstation.

## 1.7 Further protective devices

### INFORMATION

Emergency strategy – interrupt the power grid connection!

To determine the type of switch used or the switch combination installed, please refer to the connection sketch. → From page 48, section »Annex«.

Overview of switch types

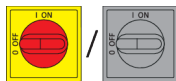
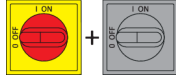
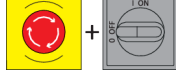
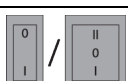
Switch	Designation	Interrupting the power grid connection
	>Mains isolator< [36] (red-yellow) or >Mains isolator< [36] (grey)	Turn the >Mains isolator< [36] to the "0" position.
	>Mains isolator< [36] (red-yellow) and additional >Appliance switch< [37] (gray):	Turn the >Mains isolator< [36] to the "0" position, then the >Appliance switch< [37] to the "0" position.
	>Emergency stop switch< [70] (red-yellow) and >Mains isolator< [36] (gray):	Press the >Emergency stop switch< [70], then set the >Mains isolator< [36] to the "0" position.
	>Power switch< [37]	<b>Power connection via socket:</b> Pull the plug, then set the >Power switch< [37] to the "0" position. <b>Connection via hard wiring:</b> Use the building's circuit breaker, then set the >Power switch< [37] to the "0" position.
–	Without a switch or inside a protective housing	<b>Power connection via socket:</b> Pull the plug. <b>Power connection via hard wiring:</b> Use the building's circuit breaker.

## 2 Commissioning

### 2.1 In-plant transport

#### CAUTION

Accessories are not transported / moved in accordance with the specifications in these operation manual

#### INJURIES DUE TO CRUSHING

- Always transport / move accessories in accordance with the specifications in these operation manual.
- Wear personal protective equipment during transport.

#### NOTE

Accessories are transported in a horizontal position

#### PROPERTY DAMAGE

- Only transport accessories in an upright position.

#### NOTE

Transport of filled temperature control unit and/or accessory

#### MATERIAL DAMAGE DUE TO OVERFLOWING HEAT TRANSFER FLUID

- Only transport empty temperature control unit and/or accessory.

- If available, use the eyes on the top side of the accessory for transportation.
- Use an industrial truck for transportation.
- The casters (if present) on the accessory are not suitable for transportation. The casters are each symmetrically loaded with 25% of the total mass of the accessory.
- Remove the packing material (e.g. the palette) only at the place of installation.
- Protect the accessory from transport damage.
- Do not transport the accessory alone and not without aids.
- Check the load bearing capacity of the transportation route and the place of installation.
- The parking brakes at the casters (if present) must be activated and/or the leveling feet (if present) must be unscrewed/activated before the temperature control unit is put into operation. → Page 22, section »Activating the leveling feet«.

#### 2.1.1 Lifting and transporting the accessories

##### 2.1.1.1 Accessories with lifting eyes

#### NOTE

The accessories are lifted at the lifting eyes without load handling equipment

#### DAMAGE TO THE ACCESSORY

- Use load handling equipment to lift and transport the accessory.
- The lifting eyes are only designed for a load **without** inclination (0°).
- The load handling attachment used must be adequately dimensioned. Take the dimensions and weight of the accessory into account.

Example: lifting eyes  
(round, angular, and  
recessed (left to right))

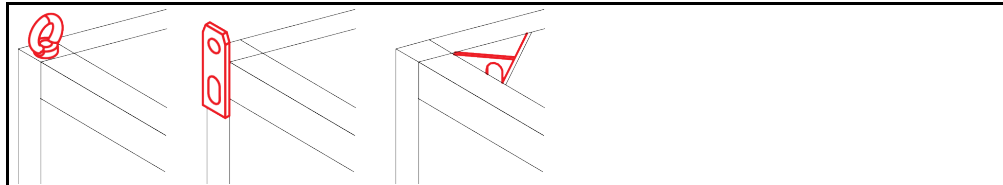

- Never lift and transport the accessory on the lifting eyes on your own and without aids.
- Lift and transport the accessory at the lifting eyes only with a crane or an industrial truck.
- The lifting force of the crane or industrial truck must correspond at least to the weight of the accessory. You will find the weight of the accessory on the data sheet. → From page 48, section »Annex«.
- If the leveling feet have been removed for shipping: Only lower the accessory when all leveling feet have been installed. → Page 18, section »Mounting/removing leveling feet«.

2.1.1.2 Accessories without lifting eyes

Example: Supporting points for forklift arms for free-standing models from a certain overall size. For the exact position please refer to the wiring diagram in the annex.

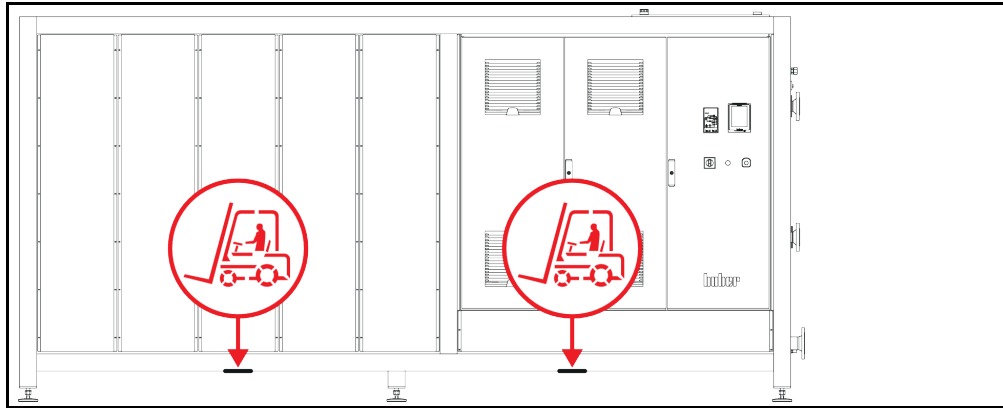

- Do not lift and transport the accessory on your own and without aids.
- Lift and transport the accessory only with an industrial truck.
- The industrial truck must have a lifting force equal to or greater than the weight of the accessory. You will find the weight of the accessory on the data sheet. → From page 48, section »Annex«.
- If the leveling feet have been removed for shipping: Only lower the accessory when all leveling feet have been installed. → Page 18, section »Mounting/removing leveling feet«.

2.1.2 Mounting/removing leveling feet

Only valid if the leveling feet have been removed for shipping.



**WARNING**

The temperature control unit/accessory is not secured against sliding and/or lowering  
**DEATH OR SERIOUS INJURY DUE TO CRUSHING**

- Secure the temperature control unit/accessory against slipping and/or lowering before installing the leveling feet.
- Do not stand or lie down under the temperature control unit/accessory for installation.

Example: mounting the leveling feet

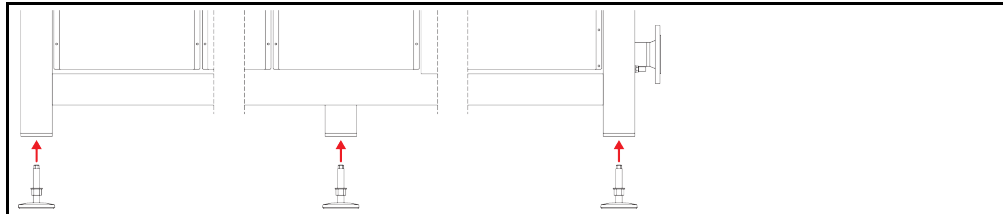

**INFORMATION**

The leveling feet were dismantled for shipping the temperature control unit/accessory. Before putting down / positioning the temperature control unit/accessory, all leveling feet must be mounted. If the temperature control unit/accessory is re-shipped: Dismantle all leveling feet prior to packaging.

- The leveling feet can only be mounted while the temperature control unit/accessory is lifted.
- Secure the temperature control unit/accessory against sliding and/or lowering.
- Do not stand or lie underneath the temperature control unit/accessory during installation of the leveling feet.
- Only lower the temperature control unit/accessory when all leveling feet have been installed.

2.1.3 Positioning the accessories

2.1.3.1 Accessories with casters

- Do **not** use the casters for transportation to the place of installation. → Page 17, section »Lifting and transporting the accessories«.
- Use the casters only for positioning at the place of installation.
- Only move the accessory on the casters when the surface is level, without gradient, non-slip and stable.
- Do not move the accessory on your own.

- **At least 2 persons** are required to move the accessory on the casters. **At least 5 persons** are required to move the accessory on the casters if the total weight of the accessory **exceeds 1.5 tons**.
- The parking brakes at the casters must be activated before the accessory is put into operation.

### 2.1.3.2 Accessories with casters including leveling feet

- Do **not** use the casters for transportation to the place of installation. → Page 17, section »**Lifting and transporting the accessories**«.
- Use the casters only for positioning at the place of installation.
- Only move the accessory on the casters when the surface is level, without gradient, non-slip and stable.
- Do not move the accessory on your own.
- **At least 2 persons** are required to move the accessory on the casters. **At least 5 persons** are required to move the accessory on the casters if the total weight of the accessory **exceeds 500 kg**.
- The accessory is equipped with casters without locking brakes. Prior to putting the accessory into operation, unscrew/activate the integrated leveling feet. → Page 22, section »**Activating the leveling feet**«.

### 2.1.3.3 Accessories without casters

- An industrial truck must be used for positioning the accessory.
- Do not move the accessory on your own.
- **At least 2 persons** are required to move the accessory.
- The industrial truck must have a lifting force equal to or greater than the weight of the accessory. You will find the weight of the accessory on the data sheet. → From page 48, section »**Annex**«.

## 2.2 Unpacking



### WARNING

#### Commissioning damaged accessories

#### DANGER TO LIFE FROM ELECTRIC SHOCK

- Do not start up damaged accessories.
- Please contact Customer Support. → Page 47, section »**Contact data**«.

## PROCEDURE

- Check for damage to the packaging. Damage can indicate property damage to the accessory.
- Check for any transport damage when unpacking the accessory.
- Exclusively contact your forwarding agent regarding the settlement of claims.
- Observe the proper disposal of packaging material. → Page 15, section »**Proper disposal**«.

## 2.3 Ambient conditions



### CAUTION

#### Unsuitable ambient conditions / unsuitable installation

#### SERIOUS INJURY DUE TO CRUSHING

- Comply with all requirements! → Page 19, section »**Ambient conditions**« and → Page 21, section »**Installation conditions**«.

### INFORMATION

Make sure there is adequate fresh air available at the site for the accessory. The warm exhaust air must be able to escape upwards unhindered.

Use of the accessory is permitted only under normal ambient conditions in accordance with the currently valid DIN EN 61010-1.

- Use only indoors. The illuminance must be at least 300 lx.
- Installation altitude up to 2,000 meters above sea level.
- Maintain wall and ceiling clearance for adequate air exchange (dissipation of waste heat, supply of fresh air for the accessory and work area). Ensure adequate floor clearance for air-cooled accessories. Do not operate the accessory from within the box or with an inadequately dimensioned bath as this inhibits the air exchange.
- Ambient temperature values are provided on the technical data sheet; to ensure trouble-free operation, compliance with the ambient conditions is mandatory.
- Relative humidity max 80% to 32 °C and 40 °C decreasing linearly to 50%.

- Short distance to supply connections.
- The accessory must not be installed so as to hinder or prevent access to the disconnecting device (to the power grid).
- For the magnitude of the mains voltage fluctuations, refer to the datasheet. → From page 48 in the section »Annex«.
- Transient surges, as would normally occur in the power supply system.
- Installation Class 3
- Applicable degree of soiling: 2.
- Surge category II.

Wall clearances

Side	Minimum clearance in cm			
	Air cooling		Water cooling	
	[A]	[B]	[A1]	[B1]
Top	[A] 0 / -	[A] 0 / 20	[A1] 0 / -	[A1] 0 / 20
Left	[B] 0 / 20	[B] 0 / 10	[B1] 0 / 20	[B1] 0 / 20
Right	[C] 0 / 20	[C] 0 / 10	[C1] 0 / 20	[C1] 0 / 20
Front	[D] 0 / 20	[D] 0 / 10	[D1] 0 / 20	[D1] 0 / 20
Rear	[E] 0 / 20	[E] 0 / 20	[E1] 0 / 20	[E1] 0 / 20

a.) [A] - [E]: Operation without bath, [A1] - [E1]: Operation in a bath  
 b.) Values in the table: without air outlet or connections / with air outlet or connections  
 c.) Value “-” in the table: free standing

### 2.3.1 EMC-specific notes

**INFORMATION**

**Connecting cables in general**

Prerequisites for a failure-free operation of the temperature control units/accessories incl. their connections with external applications: Installation and wiring must be carried out professionally. Related topics: “Electrical safety” and “EMC-compliant wiring”.

**Cable lengths**

For flexible/fixed cable routing of more than 3 meters, the following must amongst other things be observed:

- Equipotential bonding, grounding (see also technical data sheet “Electromagnetic compatibility EMC”)
- Compliance with “external” and/or “internal” lightning/overvoltage protection.
- Design protection measures, professional cable selection (UV resistance, steel pipe protection, etc.)

**Attention:**

The operating company is responsible for compliance with national/international directives and laws. This also includes the testing of the installation/wiring required by law or standards.

This device is suitable for operation in “**industrial electromagnetic environments**”. It meets the “**immunity requirements**” of the currently applicable **EN61326-1**, which are required for this environment.

It also meets the “**interference emission requirements**” for this environment. It is a **Group 1** and **Class A** device according to the currently applicable **EN55011**.

When operating the temperature control unit in another environment, its electromagnetic compatibility can in rare cases not be ensured.

**Group 1** specifies that high frequency (HF) is only used for the function of the device. **Class A** defines the interference emission limits to be observed.

## 2.4 Installation conditions

### WARNING

**The accessory is put onto the power supply line**  
**DEATH FROM ELECTRICAL SHOCK BY DAMAGE TO THE POWER CABLE.**  
 ➤ Do not put the accessory on power cables.

### WARNING

**The leveling feet are not unscrewed/activated before turning on the accessory**  
**DEATH OR SERIOUS INJURY DUE TO CRUSHING**  
 ➤ The parking brakes at the casters (if installed) must be activated and/or the leveling feet must be unscrewed/activated before the accessory is put into operation.  
 ➤ The accessory may move if the parking brakes at the casters (if installed) are not activated and/or the leveling feet are not unscrewed/activated.

- Allow the accessory to acclimate for about 2 hours when changing from a cold to a warm environment (or vice versa). Do not turn on the accessory beforehand!
- Install upright, stable and without tilt.
- Use a non-combustible, sealed foundation.
- Keep the environment clean: Prevent slip and trip hazards.
- Wheels, if installed, must be locked after installation!
- Spilled/leaked heat transfer fluid must be disposed of immediately and correctly. Observe the proper disposal of heat transfer fluid and aids. → Page 15, section »Proper disposal«.
- Observe the ambient conditions.

## 2.5 Recommended temperature control hoses

### CAUTION

**Use of unsuitable/defective hoses and/or hose connections**  
**INJURIES**  
 ➤ Pay attention to the permissible pressure and temperature range when selecting temperature control hoses.  
 ➤ Use appropriate hoses and/or hose connections.  
 ➤ Check periodically for leaks and the quality of the hoses and hose connections and take suitable measures (replace) as required.  
 ➤ Isolate and protect temperature control hoses against contact/mechanical load.

### CAUTION

**Hot or cold heat transfer fluid and surfaces**  
**BURNS TO LIMBS**  
 ➤ Avoid direct contact with the heat transfer fluids or the surfaces.  
 ➤ Wear your personnel protective equipment (e.g. temperature-resistant safety gloves, safety goggles, safety footwear).

### CAUTION

**Uncontrolled formation of ice at the connections and hoses of the heat transfer fluid circuit**  
**RISK OF SLIPPING AND OVERTURNING**  
 ➤ If the temperature is controlled in the minus range, ice forms at the hoses and connections of the heat transfer fluid circuit. This occurs by condensing and freezing of atmospheric humidity.  
 ➤ Check the thickness of the ice formation. Too much ice increases the risk of the accessories tipping over. Secure the accessories against tipping over if this is the case.  
 ➤ Check the ground below the ice formation for condensation water. Collect the condensation water with a suitable container or thoroughly remove it at regular intervals. You thus prevent the danger of slipping caused by condensation.

To connect applications, use only temperature control hoses that are compatible with the heat transfer fluid used.

- We recommend you use only temperature-insulated temperature control hoses with your accessory. The user is responsible for the insulation of connection valves.

## 2.6 Wrench sizes and torques

Sizes of the connections vary depending on the model. Please refer to the table for the correct wrench sizes and torques. The maximum torque values must **not** be exceeded. To avoid twisting the connections during assembly, they must be secured by holding them in place. Carry out a leak test after connecting.

Overview Wrench size and torques	Connection	Sleeve nut wrench size	Connector wrench size	Recommended torques in Nm	Maximum torques in Nm
	M16x1	19	17	30	35
	M24x1.5	27	27	47	56
	M30x1.5	36	32	79	93
		36	36	79	93
	M38x1.5	46	41/46	130	153
	M45x1.5	50	50	200	210
G-thread (flat-sealing)	Adapt the torque to the material of the flat seal used. Only hand-tighten the connection at first. When using adapter pieces, do not overtighten the G thread. To avoid twisting the adapter piece during installation, it must be secured by holding them in place.				

## 2.7 Preparations for operation

### 2.7.1 Activating the leveling feet

Only valid for temperature control units with extendible leveling feet.



**WARNING**

**The leveling feet are not unscrewed/activated before turning on the accessory**

**DEATH OR SERIOUS INJURY DUE TO CRUSHING**

- The parking brakes at the casters (if installed) must be activated and/or the leveling feet must be unscrewed/activated before the accessory is put into operation.
- The accessory may move if the parking brakes at the casters (if installed) are not activated and/or the leveling feet are not unscrewed/activated.

Ensure that the leveling feet are unscrewed/activated before you operate the accessories. Uneven floors can be compensated for by adjusting these leveling feet.

## PROCEDURE

- Ensure that the locking brakes of the casters (if present) are activated.
- Turn the casters inwards so that you can easily reach the red setting wheels.
- Turn the red setting wheel on each caster clockwise. This extends the leveling feet. Rotate the red wheel counterclockwise to retract the leveling feet.
- Compensate uneven floors by adjusting the leveling feet, if necessary. Use a spirit level to level the accessory horizontally.

### 2.7.2 Connecting the accessory to the temperature control unit

Example:  
Single circuit control

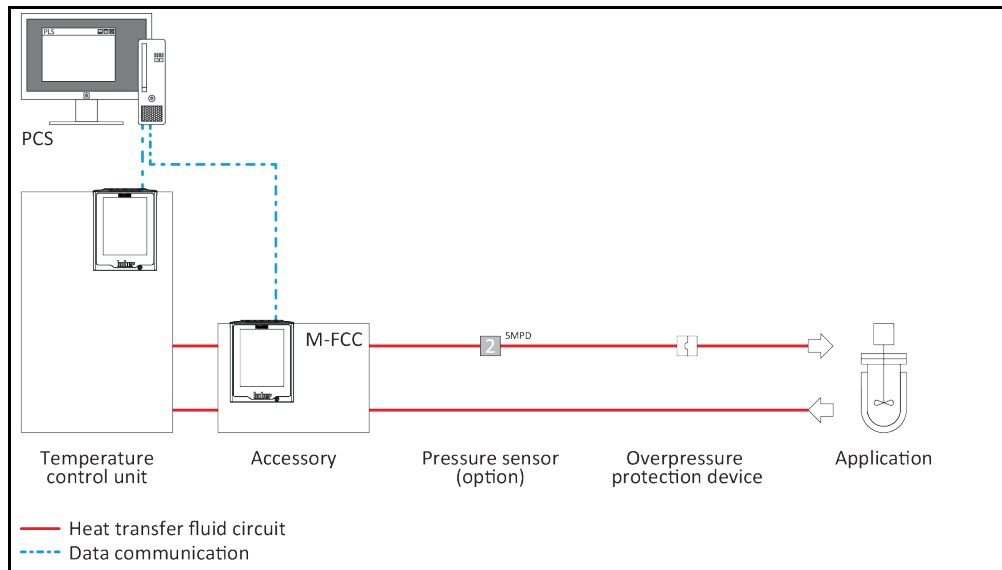

Example:  
Multi-circuit control.  
Combination of FCC  
and M-FCC: 2 max.;  
use of M-FCC only: 4  
max.

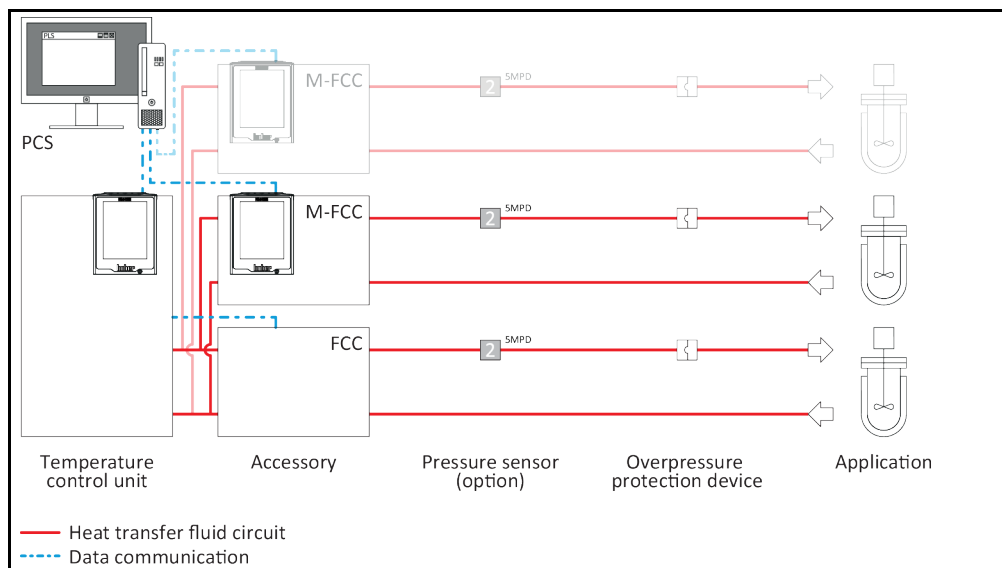

**INFORMATION**

The temperature control unit and the accessory **must** be controlled by means of a process control system.

**INFORMATION**

Follow the operation manual of the temperature control unit when connecting the device. Only use temperature control hoses that match the specifications of the heat transfer fluid used. Avoid bending / squeezing the temperature control hoses. Use suitable angle pieces and lay the hose connections with a large radius. Take the minimum bending radius from the data sheet of the temperature control hoses used. Make sure the temperature control hoses are attached to the respective unit connections such that they cannot slip off. Secure the temperature control hoses with hose clamps.

**INFORMATION**

Depending on the model: Connect an external pressure sensor to the “**external pressure sensor**” port of the accessory (otherwise the internal pressure sensor in the accessory takes control).

## PROCEDURE

- Make sure that the temperature control unit has not yet been filled with heat transfer fluid.
- Disconnect the temperature control unit from the power grid connection.
- Remove the protective caps from the connections on the accessory.
- **Single circuit and multi-circuit control (only the first accessory):**
- Connect the >Circulation flow< [1] on the temperature control unit to the >Circulation return< [2] on the accessory.
- Connect the >Circulation return< [2] on the temperature control unit to the >Circulation flow< [1] on the accessory.
- **Multi-circuit control only:**
- Install each additional accessory with the aid of T-connectors in parallel in the heat transfer fluid circuit. Note the illustration "Multi-circuit control".
- **Single circuit and multi-circuit control:**
- Connect the >Circulation flow< [1] on the accessory to an external application. For further information, please refer to the operation manual of the temperature control unit. The maximum pump pressure may be applied to your external application if the accessory is defective. An overpressure protection device must be installed in the supply line (pressure side) to protect your external application. In the event of a fault, the installed overpressure protection device protects the external application against damage. Ensure that the emerging heat transfer fluid can be collected and disposed of. → Page 15, section »Proper disposal«.
- In case you use external pressure sensors:  
Install the external pressure sensor between each accessory and the external application.
- Connect the >Circulation return< [2] on the accessory to an external application to close the heat transfer fluid circuit. For further information, please refer to the operation manual of the temperature control unit.
- Check the connections for leaks.
- In case you use external pressure sensors:  
Connect each external pressure sensor to the >Signal external pressure sensor< [66] on the accessory. The pressure sensor and the accessory must be connected in the same heat transfer fluid circuit.

### 2.7.3 Connecting the accessory and the temperature control unit to the process control system

The accessory and the temperature control unit must be controlled/monitored by means of a process control system. The process control system must ensure that the accessory cannot be switched on and off during an ongoing temperature control process. Various connections are available on the accessory and on the temperature control unit for this purpose.

- Ethernet (PB command, Modbus TCP, OPC UA)
- Analog RS interface (PB command)
- POKO and ECS (optional)  
Settings in the Pilot ONE on the accessory: POKO = "M-FCC ready" and ECS = "Status external pump"  
Settings in the Pilot ONE on the temperature control unit: POKO = "Unipump/PCS" und ECS = "Release"  
→ From page 39, section »Interfaces and software update«.

## PROCEDURE

- Connect the accessory and the temperature control unit to a process control system.

### 2.7.4 Connecting the functional ground

## PROCEDURE

- If required, connect the >functional ground terminal< [87] on the accessory with the building grounding point. Use a ground strap for this purpose. For the exact position and thread size please refer to the wiring diagram. → From page 48, section »Annex«.

## 2.8 Connecting to the power supply

**DANGER****Connecting to a power socket without protective earth (PE)****RISK OF DEATH FROM ELECTRIC SHOCK**

- Always connect the accessory to safety sockets (PE).
- In case of uncertainties about an existing protective earth (PE), have the connection inspected by a qualified (certified) electrician.
- Do not use a power cable that is longer than **3 m**.

**DANGER****Connection/adjustment through hardwiring is not carried out by a qualified (certified) electrician****RISK OF DEATH FROM ELECTRIC SHOCK**

- Have the connection/adjustment through hardwiring carried out by a qualified (certified) electrician.

**DANGER****Damaged power cable/power cable connection****MORTAL DANGER FROM ELECTRIC SHOCK**

- Do not start up the accessory.
- Isolate the accessory from the power supply.
- Have the power cable/power cable connection replaced and inspected by a qualified (certified) electrician.

**NOTE****Incorrect power supply connection****DAMAGE TO THE ACCESSORY**

- Your building's existing power supply voltage and frequency must match the data provided on the rating plate of the accessory.

**INFORMATION**

Based on local circumstances, you may have to use an alternative power cable instead of the supplied original power cable. Do not use a power cable that is longer than **3 m** to be able to disconnect the temperature control unit/accessory from the mains at any time. Have the power cable only replaced by a qualified (certified) electrician. Temperature control units/accessories with multiple mains connections must not be put into operation until all mains connections have been properly connected to a fused mains supply.

## 3 Function description

### 3.1 Function description of the accessory

#### 3.1.1 General functions

The accessory is intended for volume flow control (with or without max. pressure limit) or for pressure control of an **externally closed application**. With the parallel installation of up to 4 accessories into the heat transfer fluid circuit a multi-circuit control can be achieved. The accessory was developed for Huber temperature control units which are **not** equipped with any sensors for this control. The accessory permits sensitive external applications (e.g.: glass reactors) to be operated with a lower flow rate or pressure in normal operation. The accessory ensures a soft startup. It regulates and limits the flow rate or pressure that acts on the external application.

To avoid power losses, evaporator and heater are sufficiently circulated by the primary circuit (temperature control unit – accessory). The secondary circuit feeds the external application.

The accessory comes with one of three measuring methods: TURB (turbine), MID (magnetic-inductive flow meter) or CORE (Coriolis). The installed flow meter is specified on the data sheet. → From page 48, Section »Annex«. The "TURB"/"CORE" flow meter permits conductive and non-conductive heat transfer fluids to be used. The "MID" flow meter, in contrast, can **only** be used with conductive heat transfer fluids.

The accessory can detect pressure in two ways:

- Internal pressure sensor: Measuring point in accessory (standard).
- External pressure sensor: Measuring point is external, e.g. directly at the external application. This requires an additional pressure sensor.

#### 3.1.2 Other functions

Your temperature control unit can be easily integrated into many laboratory automation systems. This is provided for by the existing **standard interfaces Ethernet, USB device and USB host at the "Pilot ONE"**. The optionally available Com.G@te allows you to expand your accessories by **digital interfaces (RS232 and RS485), an analogue current interface (0/4 - 20 mA or 0 - 10 V) and various digital control options (In/Out)**.

The **removable control panel ("Pilot ONE")** can also be used as a **remote control**. Please contact your dealer or Huber Sales Department if you need an extension cable. → Page 47, section »Contact data«.

The **connection jack for Pt100 process sensors** permits the connection of a **temperature sensor** to display the temperature.

## 3.2 Information on the heat transfer fluids



### Non-compliance with the safety data sheet for the heat transfer fluid to be used

#### INJURIES

- Risk of injury to the eyes, skin, respiratory tract.
- The safety data sheet for the heat transfer fluid to be used must be read prior to using it and its content must be respected.
- Observe the local regulations/work instructions.
- Wear your personal protective equipment (e.g. temperature-resistant safety gloves, safety goggles, safety footwear).
- Danger of slipping because floor and work area are contaminated. Clean the workplace; observe the proper disposal of heat transfer fluid and aids. → Page 15, section »Proper disposal«.

**CAUTION****The temperature range of the accessory is exceeded****BURNS OF LIMBS**

- The temperature range of the employed temperature control unit is limited by the use of the accessory.
- Do not exceed the temperature range of the accessory (see data sheet). → From page 48, Section »Annex«.
- Select the upper temperature limit on the temperature control unit. Adapt the maximum set-point in the Pilot ONE for this.
- Wear your personal protective equipment (e.g. temperature-resistant safety gloves, safety goggles, safety footwear).

**NOTE****Non-compliance with the compatibility between the heat transfer fluid and your accessories****MATERIAL DAMAGE**

- Take note of the heat transfer fluid that is preselected in the accessories (see rating plate on the accessories).

**NOTE****Mixing different heat transfer fluids in a heat transfer fluid circuit****PROPERTY DAMAGE**

- Do **not** mix different types of heat transfer fluid (such as mineral oil, silicone oil, synthetic oil, water, etc.) in a heat transfer fluid circuit.
- The heat transfer fluid circuit **must** be rinsed when changing from one type of heat transfer fluid to another. No residues of the previous type of heat transfer fluid may remain in heat transfer fluid circuit.

**INFORMATION**

For heat transfer fluids we recommend the media listed in the Huber catalog. The name of a heat transfer fluid results from its working temperature range and the viscosity at 25 °C.

The "TURB" flow meter can be used with conductive and non-conductive heat transfer fluid! The heat transfer fluid is preselected at the factory. For example: Water-ethylene glycol mixture, DW-Therm, etc. The "MID" flow meter can **only** be used with conductive heat transfer fluid! The flow meter adjusts automatically to the currently used heat transfer fluid. For example: Water, water ethylene glycol mixture, etc.

The flow meter your accessory is equipped with and the temperature range in which it can be used are specified on the data sheet. → From page 48, section »Annex«.

The heat transfer fluid preset in the "TURB" flow meter is indicated on the rating plate on the accessory. These presettings must be changed when you change to another heat transfer fluid. To do this, call Customer Support. → Page 47, section »Contact data«. After you have changed to a different heat transfer fluid, attach a clearly visible note to the accessory that indicates the newly selected heat transfer fluid!

### 3.3 To be noted when planning the test

**INFORMATION**

Please also note: → Page 13, section »Extension of specified normal operation«.

The focus is on your application. Bear in mind that system performance is influenced by heat transfer, temperature, heat transfer fluid viscosity, volume flow, and flow speed.

- Make sure that the electrical connection is adequately dimensioned.
- The place of installation of the accessory should be selected so as to ensure adequate fresh air.
- A cross-section reduction or shut-off in the heat transfer fluid circulation must be avoided.
- To prevent the danger of over-pressure in the system, the heat transfer fluid must always be brought to room temperature before switching off. This will prevent damage to the temperature control device, accessory, or the application. Any isolating valves must remain open (pressure equalization).
- Select the heat transfer fluid to be used in such a way that it not only permits the minimum and maximum working temperature but is also suitable with regard to fire point, boiling point, and viscosity. In addition, the heat transfer fluid must be compatible with all the materials in your system.
- Avoid bending the temperature control and cooling water hoses (if required). Use suitable angle pieces and lay the hose connections with a large radius. Take the minimum bending radius from the data sheet of the temperature control hoses used.
- The selected hose connections must be resistant to the heat transfer fluid, the working temperatures and the permitted maximum pressure.
- Check the hoses at regular intervals for any material fatigue (e.g. cracks, leaks).

### 3.4 “Pilot ONE®” controller

Please note the figure “Pilot ONE”. → Page 6.

#### 3.4.1 Functional overview of “Pilot ONE®”

Overview of the E-grade variants

Accessory/E-grade	E-grade Basic	E-grade Exclusive	E-grade Professional
Multi Flow Control Cube	X	O	O
<b>E-grade “DV-E-grade”</b> – All interface commands are enabled. – Temperatures in 0.001 C, volume flows in 0.001 l/min possible (cf. E-grade Explore) <b>Note:</b> Only the interface commands are enabled, not the corresponding menu items in Pilot ONE!	O	O	O
<b>E-grade “OPC-UA”</b> – OPC-UA interface via Ethernet. This E-grade additionally includes DV-E-grade functionalities.	O	O	O
X = Standard equipment, O = optional, – = not possible			

Overview of E-grade functions

Function	E-grade Basic	E-grade Exclusive	E-grade Professional
<b>Temperature control</b>			
Sensor calibration for external sensor <sup>1</sup> : x -point	2	5	5
Ventilation program	X	X	X
<b>Display &amp; operation</b>			
Temperature display: 5.7" Touchscreen	X	X	X
Display mode: graphically / numerically large / Explore	–/X/–	–/X/–	X/X/–
Display resolution: 0.1 °C / 0.01 °C	X/–	X/X	X/X
Graphic display for temperature curves: Window, full screen and scalable	X	X	X
Calendar, date and time	X	X	X
Language: CZ, DE, EN, ES, FR, IT, JP, KO, PL, PT, RU, TR, ZH	X	X	X
Temperature format switchable: °C, °F and K	X	X	X
Display mode (screen) can be switched by swiping	X	X	X
Favorites menu	X	X	X
User menu (administrator level)	–	–	X
<b>Connections</b>			
Digital interface RS232	X	X	X
USB interfaces: Host and device	X	X	X
Ethernet RJ45 interface	X	X	X
Pt100 external sensor connection	X	X	X
External control signal (ECS STANDBY <sup>2</sup> )	X	X	X

<sup>1</sup> External Pt100.

<sup>2</sup> Via optional Com.G@te or POKO/ECS interface.

Function	E-grade Basic	E-grade Exclusive	E-grade Professional
Programmable potential-free contact (ALARM <sup>1</sup> )	X	X	X
AIF (analog interface) 0/4–20 mA or 0–10 V <sup>2</sup>	X <sup>3</sup>	X	X
Digital interface RS485 <sup>4</sup>	X	X	X
<b>Comfort &amp; other</b>			
Visual / audible alarm signal	X	X	X
Plug & Play technology	X	X	X
Technology glossary	X	X	X
Remote control / data visualization via Spy software	X	X	X
E-grade evaluation versions available (valid for 30 days)	X	X	X
Copying settings	–	–	X
Service data recorders (flight recorder)	X	X	X
PB commands <sup>5</sup>	X	X	X
Communication watchdog	–	–	X
Process data recording directly to a USB stick: Setpoint, Actual Value Internal and Actual Value Process / Heating Capacity %, Cooling Capacity %, and Pump Pressure / Pump Speed, and VPC Pressure	–/–/–	X/X/–	X/X/X

## 3.5 Clock/event function

### 3.5.1 Rechargeable accumulator

“Pilot ONE” is equipped with a clock that continues to run even when the accessory is switched off. The energy required for this is provided by a rechargeable battery, which is automatically charged when the accessory is switched on. The rechargeable battery has been dimensioned so that the clock can continue to run even if the accessory is switched off over longer intervals (up to several months). If the accessory was off for a very long time and time and date have been deleted, it is usually sufficient to leave the accessory on for several hours (no temperature control/control is necessary for this). During this time you can already reset time and date.

If after switching the unit off and back on again, the previously set time and date re-appear, it can be safely assumed that the rechargeable accumulator is defective. In this case, please contact Customer Support. → Page 47, section »Contact data«.

## 3.6 Operation via the touch screen

The entire operation is via the >Touchscreen< [88]. These functions can be activated by tapping the displayed text boxes/icons once. This also changes the display.

### INFORMATION

You can cancel the current dialog or dialog sequence at any time by pressing the “ESC” touch button. When canceling a dialog or dialog sequence, it may be necessary to confirm the cancellation again. When canceling a dialog sequence, settings made earlier in the dialog sequence are discarded. Check your already carried out settings and re-enter as needed.

<sup>1</sup> Via optional Com.G@te or POKO/ECS interface.

<sup>2</sup> Via optional Com.G@te.

<sup>3</sup> Restricted, see entries under “Temperature Control”.

<sup>4</sup> Via optional Com.G@te.

<sup>5</sup> See Data Communication Manual. Anything controllable via the graphical user interface of the Pilot ONE can be controlled by PB commands. Even without DV- or Explore-E-grade, the PB commands “vFluidFlow” and “vFluidFlowSet” can be used with the accessory.

### 3.7 Display instruments

Display instruments

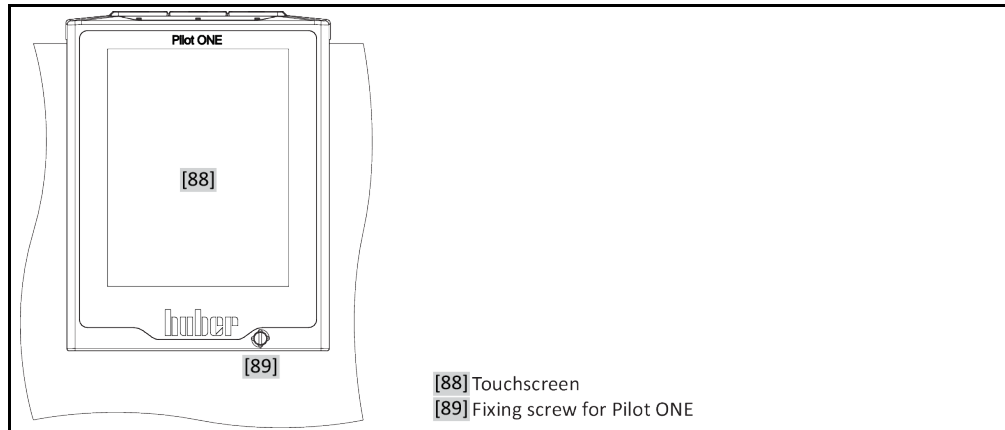

#### 3.7.1 The touchscreen [88]

The most important display and operating instrument. Shows both standard variables (setpoint, actual value, setpoint thresholds...), and also menu guidance, error information output and operation.

### 3.8 Control instruments

Example "Control instruments"

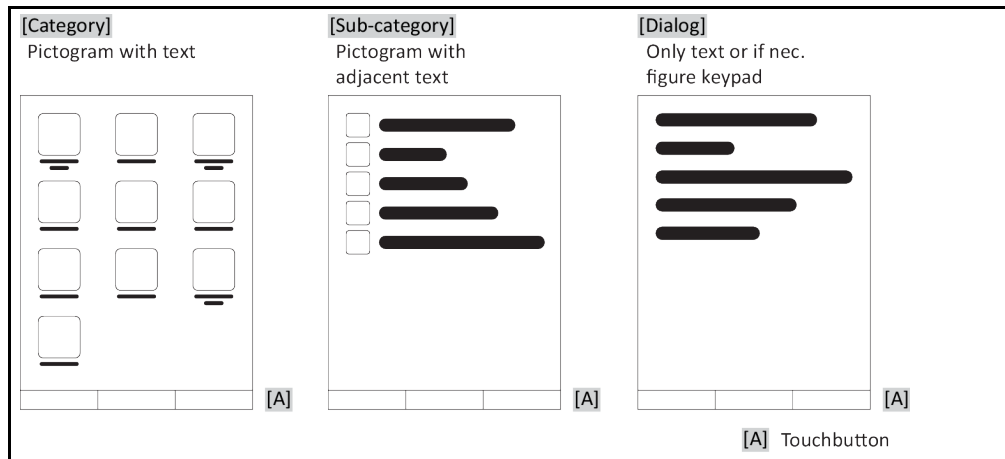

**INFORMATION**

To exit the "Categories Menu", sub-categories, menu items, press the "Home" touch button (house) or the arrow. After 2 minutes of inactivity, the category/ sub-category or the Favourites menu is automatically closed and you return to the "Home" screen. Dialogs are **not** canceled/closed after 2 minutes of inactivity.

#### 3.8.1 The touchbuttons

Depending on the situation, the touch buttons can be assigned different functions. For example:

- Select the "Home" screen (house)
  - Back (arrow to left)
  - Favourites (star)
  - Add to favorites (star with a plus sign)
  - Select the "Categories menu" (menu)
  - Confirm entry
  - Start/stop
- etc.

### 3.8.2 The categories

For clarity we have grouped the Operation and Setting of Pilot ONE in various categories. A category is selected by tapping it.

### 3.8.3 The sub-categories

The sub-categories are parts of a category. This is where you will find the entries that we have grouped together for you in the selected category. Not all the categories also contain sub-categories. Tap on a sub-category to select it.

### 3.8.4 The dialogs

Tapping on a category or sub-category displays its dialogs. Dialogues may appear e.g. as text, a numeric or a alphanumeric keyboard. Dialogs allow you for example to enter settings or start created temperature control programs. Within a dialog, selection must always be confirmed with the "OK" touch button. When cancelling a dialog with the "ESC" touch button it may be necessary to confirm the cancellation again.

## 3.9 Function examples

### 3.9.1 Display of software version

#### PROCEDURE

- Go to the "Categories Menu".
- Tap on the category "System Settings".
- Tap on the category "System Info".
- Tap on the sub-category "Software Version".

The software versions of the electronics will be displayed:

Display of software versions

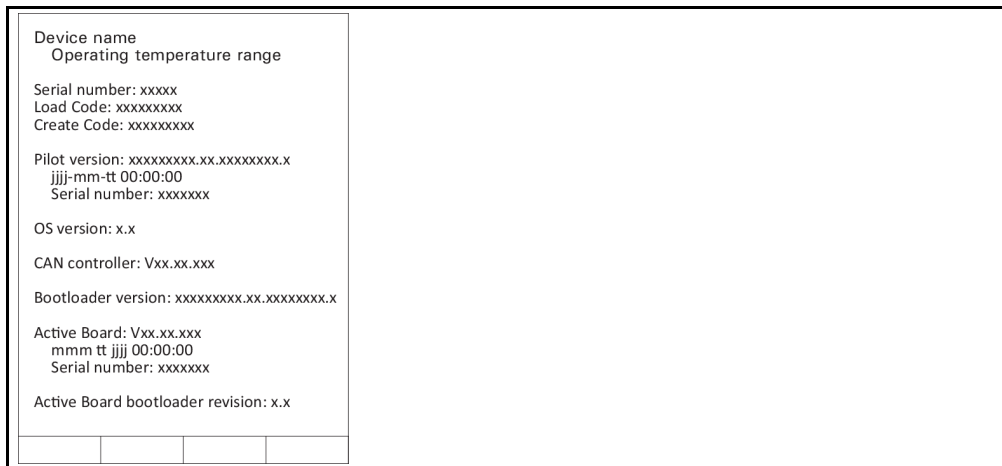

- Tap either the "ESC" or "OK" touchbutton. You will be returned to the previous screen.
- Tap on the "Home" touchbutton (house) to return to the "Home" screen.

### 3.9.2 Settings via "Category menu"

#### INFORMATION

If the accessory is not equipped with a "Pilot ONE®", all settings are made on the temperature control unit. Otherwise, the settings are made directly on the accessory. **The functions described below depend on the model used.**

Accessory with multi-circuit control (> 2 heat transfer fluid connections): Settings are made separately for each subsystem. Simply select the desired subsystem.

## PROCEDURE

- Go to the “Categories menu”.
- Tap on the category “System settings”.
- Tap on the category “\* settings”. \* = VPC, FCC or M-FCC.
- Tap on the category “Subsystem”. Only available with multi-circuit control. ...

### 3.9.2.1 Setting the “Control mode”

## PROCEDURE

- ... Tap the sub-category “Control mode”.
- Select the desired control mode. The following are available: “Disable control”, “Pressure control”, “Flow control” and “Flow control (pressure limit)”.
- Tap “OK” to confirm your selection.

### 3.9.2.2 Setting the “Pressure setpoint”

## PROCEDURE

- ... Tap the sub-category “Pressure setpoint”.
- Enter the new value (bar).
- Tap “OK” to confirm your entry.

### 3.9.2.3 Setting the “Flow setpoint”

## PROCEDURE

- ... Tap the sub-category “Flow setpoint”.
- Enter the new value (l/min).
- Tap “OK” to confirm your entry.

### 3.9.2.4 Setting the “Pressure control parameter”

## PROCEDURE

- ... Tap the sub-category “Pressure control parameter”.
- Enter the new values for “KP”, “KI” and “KD” here one after the other.
- Tap “OK” to confirm your entry.

### 3.9.2.5 Setting the “Flow control parameter”

## PROCEDURE

- ... Tap the sub-category “Flow control parameter”.
- Enter the new values for “KP”, “KI” and “KD” here one after the other.
- Tap “OK” to confirm your entry.

### 3.9.2.6 Displaying the settings

## PROCEDURE

- ... Tap the sub-category “Display”. The overview shows all the settings. “n/v” stands for “Control disabled”, “p” for “Pressure control”, “V” for “Flow control” and “V’,pMax” for “Flow control (pressure limit)”. A multi-circuit control displays the various subsystems.
- Tap on “OK” after you have read/checked the settings.

### 3.9.2.7 Resetting control parameters

## PROCEDURE

- ... Tap the sub-category “Reset control parameter”.
- Read the information. To cancel, tap either “No” or “ESC”.
- Tap “OK”. All control parameters will be reset to their factory settings. With multi-circuit control, only the parameters of the selected subsystem will be reset.

### 3.9.3 Settings via “Home screen”

**INFORMATION**

If the accessory is not equipped with a “Pilot ONE®”, all settings are made on the temperature control unit. Otherwise, the settings are made directly on the accessory.

#### 3.9.3.1 Changing the “Control mode”

## PROCEDURE

### Single circuit control

- Tap the “Mode” icon.
- Select the desired control mode. The following are available: “Pressure control”, “Flow control” and “Flow control (pressure limit)”.
- Tap “OK” to confirm your selection.

### Multi-circuit control

- Tap the number of the subsystem. The number of subsystems depends on the model.
- Select the desired control mode for the subsystem. The following are available: “Disable control”, “Pressure control”, “Flow control” and “Flow control (pressure limit)”. This selection applies only to this subsystem.
- Tap “OK” to confirm your selection.

#### 3.9.3.2 Changing the “Pressure setpoint” or “Flow setpoint”

## PROCEDURE

### Single circuit control

- Tap the “3 way valve” icon. It is located above the “Mode” icon. Depending on the selected control mode, a new setpoint is entered for “Flow control” (l/min) or for “Pressure control” (bar).
- Enter the new value (l/min or bar).
- Tap “OK” to confirm your entry.

### Multi-circuit control

- Tap the value of the subsystem. The displayed values vary depending on the selected control mode. “l/min” stands for “Flow control”, “bar” for “Pressure control”. “n/v” stands for “Control disabled”, “p” for “Pressure control”, “V” for “Flow control” and “V’,pMax” for “Flow control (pressure limit)”. A multi-circuit control displays the various subsystems.
- Enter the new value (l/min or bar).
- Tap “OK” to confirm your entry.

## 4 Setup mode

### 4.1 Setup mode

**CAUTION**

**Moving the accessory during operation**  
**SERIOUS BURNS/FREEZING DUE TO HOUSING PARTS/ESCAPING HEAT TRANSFER FLUID**  
 ➤ Do not move the accessory when in operation.

**NOTE**

**When the accessory is switched off, the heat transfer fluid temperature is higher/lower than the room temperature**  
**MATERIAL DAMAGE TO THE ACCESSORY**  
 ➤ Use the temperature control unit to temper the heat transfer fluid in the accessory to room temperature (20 °C).  
 ➤ Do not close the isolating valves in the heat transfer fluid circuit.

**NOTE**

**A pressure-sensitive external application is run with the accessory without an overpressure protection device being installed**  
**MATERIAL DAMAGE TO THE EXTERNAL APPLICATION**  
 ➤ To protect a pressure-sensitive external application (such as a glass apparatus), use an overpressure protection device in the supply line.  
 ➤ Do not use accessories as an isolating valve. The outputs cannot be completely closed due to the design.  
 ➤ The external application can be damaged by excessive pressure if the return is locked.

**NOTE**

**The accessory is switched on or off while temperature control is ongoing**  
**MATERIAL DAMAGE TO THE EXTERNAL APPLICATION**  
 ➤ A system test is run when the accessory is switched on. If temperature control was active, this would cause the uncontrolled pressure to be applied to the external application. This must be avoided at all cost!  
 ➤ Do not switch the accessory on or off while a temperature control process is active at the temperature control unit.  
 ➤ The accessory may only be switched on or off if **no** temperature control is active at the temperature control unit.

**INFORMATION**

The accessory is only operated via the **>Touchscreen< [88]** in setup mode. In normal mode, temperature control unit and accessory must be controlled by means of a process control system.

#### 4.1.1 Turning on the accessory

**NOTE**

**The control is started at the accessory before filling**  
**DAMAGE TO THE ACCESSORY**  
 ➤ Dry running can damage the accessory if the temperature control unit and the accessory are not filled.  
 ➤ Start the control at the accessory only **after** filling.

Display of the set control mode

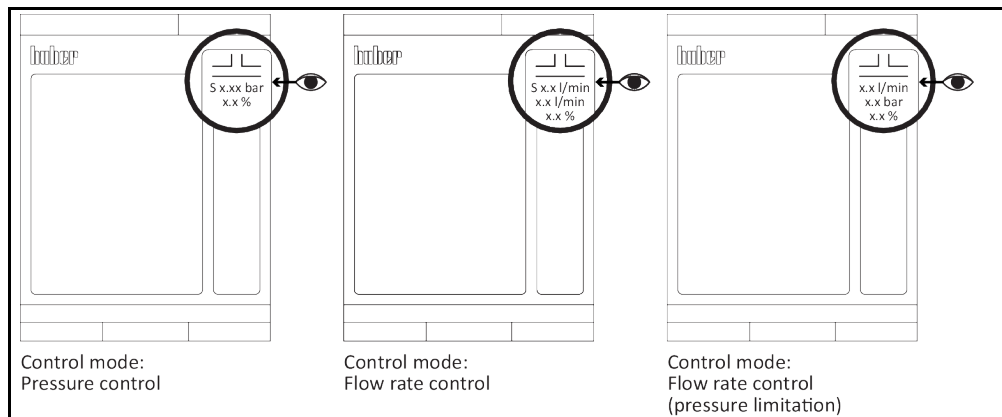

## PROCEDURE

- Check whether all operation preparation steps have been taken. → Page 22, section »Preparations for operation«.
- Connect the accessory with the building power grid connection.
- Switch on the accessory using the >Mains switch< [37].  
After the accessory has been switched on, a system test/initialization process takes place to test the full functionality of the accessory. A message appears on the >Touchscreen< [88] in case of an error or if a warning is issued. In case of doubt, please contact Customer Support. → Page 47, section »Contact data«.

### INFORMATION

The following data entry is required only for:

- a.) initial start-up
- b.) resetting the accessory to the factory settings.

- After switching on the accessory, tap on the required system language.
- Touch "OK" to confirm your selection.
- Read the information and confirm by touching "OK".
- Tap the time zone that is applicable to you.
- Touch "OK" to confirm your selection.
- Enter the current date and time.
- Touch "OK" to confirm your entry.
- Tap on the heat transfer fluid used.
- Tap "OK" to confirm your selection.
- Set the desired control mode.
- Set the required setpoints.
- Continue with switching on/setting up the temperature control unit. Follow the instructions in the enclosed documentation.

### 4.1.2 Switching off the accessories

## PROCEDURE

- Control the temperature of the heat transfer fluid to room temperature.
- Stop the control at the accessory. This closes the output. However the output cannot be completely closed due to the design.
- Check whether the >Touchscreen< [88] at the accessory displays the value "0.0 %" during control mode. If the value is higher, the accessory may **not** be switched off via the >Mains switch< [37]!
- Switch off the accessory using the >Mains switch< [37] only when the value "0.0 %" is displayed during control mode.

## 4.2 Filling and draining the accessory

### CAUTION

**Extremely hot or cold surfaces, connections and heat transfer fluids**

#### BURNS OR FREEZING OF LIMBS

- Surfaces, connections and the tempered heat transfer fluid can be extremely hot or cold depending on the operating mode.
- Avoid direct contact!
- Wear personnel protective equipment. For example heat-resistant protective gloves and safety goggles.

### CAUTION

**Non-compliance with the safety data sheet for the heat transfer fluid to be used**

#### INJURIES

- Risk of injury to the eyes, skin, respiratory tract.
- The safety data sheet for the heat transfer fluid to be used must be read prior to using it and its content must be respected.
- Observe the local regulations/work instructions.
- Wear your personal protective equipment (e.g. temperature-resistant safety gloves, safety goggles, safety footwear).
- Danger of slipping because floor and work area are contaminated. Clean the workplace; observe the proper disposal of heat transfer fluid and aids. → Page 15, section »Proper disposal«.

**NOTE**

**During an active circulation, the heat transfer fluid circuit is shut off by shut-off valves**  
**MATERIAL DAMAGE TO THE CIRCULATING PUMPS INSTALLED IN THE TEMPERATURE CONTROL UNIT**

- Do not close the heat transfer fluid circuit during an active circulation by means of shut-off valves.
- Warm the heat transfer fluid to room temperature before stopping the circulation.

#### 4.2.1 Filling the accessory

**NOTE**

**The control is started at the accessory before filling**  
**DAMAGE TO THE ACCESSORY**

- Dry running can damage the accessory if the temperature control unit and the accessory are not filled.
- Start the control at the accessory only **after** filling.

### PROCEDURE

- Check whether all the steps were implemented. → Page 22, section »Preparations for operation«.
- For filling, venting and degassing of the temperature control unit, proceed as described in its operation manual.
- After successful initial filling, additionally start the venting process at the accessory. The venting process takes into account the setpoints set at the accessory beforehand (depending on the control mode set). → Page 34, section »Turning on the accessory«.
- Go to the “Categories menu”.
- Touch the category “M-FCC”.
- Touch the category “Start/Stop”.
- Touch the dialog entry “Start venting”.
- Touch “OK” to confirm your selection.
- Proceed as described in the operation manual of the temperature control unit.
- After adequate filling, additionally stop venting at the accessory.
- Go to the “Categories menu”.
- Touch the category “M-FCC”.
- Touch the category “Start/Stop”.
- Touch the dialog entry “Stop venting”.
- Touch “OK” to confirm your selection.

#### 4.2.2 Draining the accessory

**CAUTION**

**Hot or very cold heat transfer fluid**  
**SERIOUS BURNS/FREEZING OF LIMBS**

- Before draining, ensure that the heat transfer fluid has room temperature (20 °C).
- If, at this temperature, the heat transfer fluid is too viscous to be drained: Control the temperature of the heat transfer fluid for a few minutes until the viscosity will allow drainage.
- Danger of burns when draining heat transfer fluid at temperatures above 20 °C.
- Wear your personal protective equipment when carrying out the drainage operation.

### PROCEDURE

- Proceed as described in the operation manual of the temperature control unit when draining it. The accessory is drained via the temperature control unit. Follow the instructions for the proper disposal of heat transfer fluid. → Page 15, section »Proper disposal«.
- Additionally start the draining process at the accessory.
- Go to the “Categories menu”.
- Touch the category “M-FCC”.
- Touch the category “Start/Stop”.
- Touch the dialog entry “Drain”.
- Touch “OK” to confirm your selection.
- Wait until the temperature control unit, the application and the accessory have been drained.
- Stop the draining process at the accessory.
- Go to the “Categories menu”.
- Touch the category “M-FCC”.
- Touch the category “Start/Stop”.
- Touch the dialog entry “Drain”.
- Touch “OK” to confirm your selection.

- Proceed as described in the operation manual of the temperature control unit.
- Remove the temperature control hose from the accessory's >Circulation flow< [1].
- Remove the temperature control hose from the accessory's >Circulation return< [2].
- Remove the temperature control hose from the accessory's >Circulation flow< [1].
- Remove the temperature control hose from the accessory's >Circulation return< [2].
- Leave the accessory open for a while to allow it to dry out and the residue to drain.
- Re-connect the temperature control hose to the accessory's >Circulation flow< [1].
- Re-connect the temperature control hose to the accessory's >Circulation return< [2].
- Re-connect the temperature control hose to the accessory's >Circulation flow< [1].
- Re-connect the temperature control hose to the accessory's >Circulation return< [2].

## 5 Normal operation

### 5.1 Automatic operation

#### CAUTION

**Extremely hot or cold surfaces, connections and heat transfer fluids**

**BURNS OR FREEZING OF LIMBS**

- Surfaces, connections and the tempered heat transfer fluid can be extremely hot or cold depending on the operating mode.
- Avoid direct contact!
- Wear personnel protective equipment. For example heat-resistant protective gloves and safety goggles.

#### NOTE

**During an active circulation, the heat transfer fluid circuit is shut off by shut-off valves**

**MATERIAL DAMAGE TO THE CIRCULATING PUMPS INSTALLED IN THE TEMPERATURE CONTROL UNIT**

- Do not close the heat transfer fluid circuit during an active circulation by means of shut-off valves.
- Warm the heat transfer fluid to room temperature before stopping the circulation.

#### INFORMATION

In normal mode, temperature control unit and accessory **must** be controlled by means of a process control system.

#### 5.1.1 Temperature control

##### 5.1.1.1 Starting the temperature control process

Temperature control by the temperature control unit and control by the accessory are started by means of a process control system. Prerequisite: The temperature control unit and the accessory are connected with a process control system, are switched on (initialization process for the accessory is completed) and are filled/vented.

### PROCEDURE

- Start the temperature control process as described in the operation manual of the temperature control unit.

##### 5.1.1.2 Ending the temperature control process

#### NOTE

**When the accessory is switched off, the heat transfer fluid temperature is higher/lower than the room temperature**

**MATERIAL DAMAGE TO THE ACCESSORY**

- Use the temperature control unit to temper the heat transfer fluid in the accessory to room temperature (20 °C).
- Do not close the isolating valves in the heat transfer fluid circuit.

The temperature control process by the connected temperature control unit continues to run after the accessory has stopped the control. The temperature control process by the temperature control unit must be stopped separately.

### PROCEDURE

- Bring the heat transfer fluid up to room temperature using the temperature control unit.
- Stop the control by the accessory. The control has only stopped completely if the control mode outputs the value "0.0 %". Only when this value is reached may the temperature control be stopped at the temperature control unit.

## 6 Interfaces and software update

**NOTE**

**Connections with the interfaces are established during operation**  
**DAMAGE TO THE INTERFACES**

- Interfaces may get damaged if devices are connected with the interfaces during operation.
- Before connecting, ensure the device to be connected is turned off.

**NOTE**

**Failure to observe the specifications of the interface used**  
**MATERIAL DAMAGE**

- Only connect components that meet the interface requirements.

**NOTE**

**The "Pilot ONE®" controller is not operated behind a firewall**  
**MATERIAL DAMAGE**

- The "Pilot ONE®" controller must be operated behind a firewall if it is connected with a high-risk network.
- The best available technology is to be applied in order to create sufficient security for the LAN!

**INFORMATION**

Please note the specifications of the generally applicable standards when using the interfaces. For the exact position of the interfaces, please refer to the wiring diagram.

**INFORMATION**

Settings of the interfaces: Settings in the "Interfaces" category can be made in the "Pilot ONE®".

**INFORMATION**

The use of PB commands is described in our manual "Data communication PB". You can download this manual under [www.huber-online.com](http://www.huber-online.com). The PB commands "vFluidFlow" and "vFluidFlowSet" can also be used with the accessory without activated DV- or Explore E-grade.

**INFORMATION**

Information on the interfaces can be found in our manual "Interfaces". You can download this manual at [www.huber-online.com](http://www.huber-online.com).

### 6.1 Firmware update

The "Pilot ONE Flasher" software to update the firmware is available under [www.huber-online.com](http://www.huber-online.com). The installation package contains instructions for the firmware update.

### 6.2 Data communication

#### 6.2.1 PB commands

Example: If several accessories are controlled/monitored by means of a process control system.

Cyclically query the accessory status (vStatus2, Bit6).  
 Start the temperature control of the temperature control unit as soon as the system test of each accessory has been completed (vTmpActive).  
 Query the status of the temperature control unit (vStatus1, Bit 4).  
 When the pump in the temperature control unit is running, the accessories can be started (e.g. with vTmpActive).

A "Locking" must be implemented in the operator control.

Possible reading commands

Variable	Description
<b>Accessories</b>	
vTE (Process temperature (Lemos))	The current process temperature is returned. Strictly speaking, the measured value of the Pt100 sensor which is connected to the LEMOSA connector is returned. Typically the processor sensor is connected here. If no sensor is connected, the value -151 °C is returned.

Variable	Description
<b>vTmpActive</b> (Temperature control)	Start or stop temperature control of the thermostat or query current status. 0: Temperature control not active 1: Temperature control active
<b>vStatus2</b> (Status of the thermostat)	Bit 6: The VPC has completed its reference point approach and you can start the pump. Message -4137 is displayed on the Pilot ONE if an attempt is made to start the pump while bit 6 returns the value 0.
<b>vpPSet</b> (Setpoint pump pressure)	Set and query the current pump pressure setpoint. Please note that this function is only available with thermostats with speed-controllable pumps or VPC bypass.
<b>vFluidFlow</b> (Heat transfer fluid volume flow)	Current measured value of the heat transfer fluid volume flow. Please note that this measured value is only available if a special volume flow measuring device is provided.
<b>vFluidFlowSet</b> (Setpoint heat transfer fluid volume flow)	Current setpoint of the heat transfer fluid volume flow. Please note that this function is only available if a special volume flow measuring device is provided. In addition, either a speed-controllable pump or a VPC bypass must be provided in order to allow control.
<b>vpVPC</b> (VPC Bypass pressure)	Absolute pressure measured in the supply line of the VPC bypass. If an external pressure sensor is connected to the VPC bypass, the value measured by that sensor is returned, otherwise the value measured by the pressure sensor in the VPC bypass (at the output of the customer's application) is returned. The return value must be reduced by 1000 mbar if a relative pressure (the difference to the atmospheric pressure) is to be processed.
<b>vPumpCtrlMode</b> (Pump control mode)	Setting and querying the pump control mode. 0: Control of pump speed. 1: Control of pump pressure. 2: Control of the heat transfer fluid flow. 3: Control of the heat transfer fluid flow rate, but limited to a maximum pressure.
<b>Temperature control unit</b>	
<b>vStatus1</b> (Status of the thermostat)	Bit 4: Circulating pump: 1: switched on / 0: switched off

## 7 Maintenance

### 7.1 Electrical fuse

For entry >Fuse< [61] in the wiring diagram: The thermal overcurrent circuit breakers have been installed to provide all-pole disconnection (L and N). If there is no function after switching on, please check the overcurrent circuit breakers. If the circuit breakers trip again after being reset, disconnect the power plug and contact our Customer Support.

### 7.2 Replacing the “Pilot ONE®”

Replacing the  
“Pilot ONE”

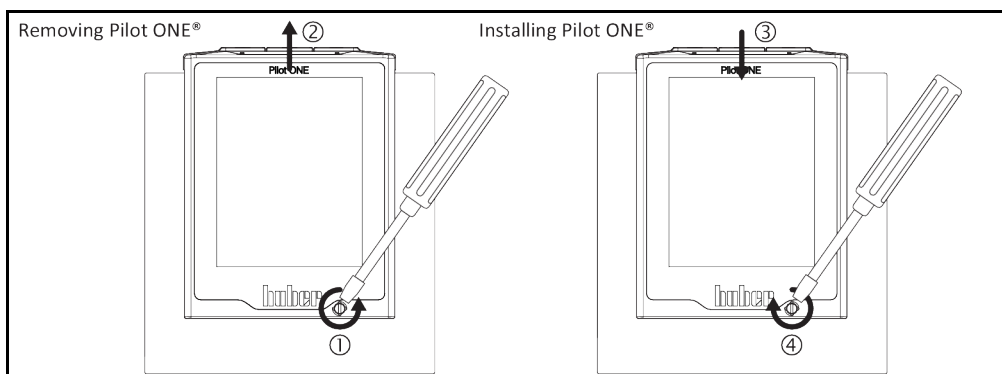

#### PROCEDURE

- Switch off the accessory.
- Disconnect the accessory from the power supply.
- Release the >Fixing screw for Pilot ONE< [89] at the front of the housing.
- Carefully pull the “Pilot ONE” away upwards.
- Carefully insert the replacement “Pilot ONE”.
- Close the >Fixing screw for Pilot ONE< [89] at the front of the housing.
- Connect the accessory to the power supply.
- Switch on the accessory.

### 7.3 Maintenance

#### **! DANGER**

**Cleaning/maintenance while the temperature control unit/ accessory is operating**

#### **DANGER TO LIFE FROM ELECTRIC SHOCK**

- Stop an ongoing temperature control process.
- Adjust the temperature of the heat transfer fluid to room temperature after switching off.
- Disconnect the temperature control unit from the power supply.
- Also disconnect the accessories from the current supply.

#### **NOTE**

**Maintenance work that is not described is carried out**

#### **MATERIAL DAMAGE**

- For maintenance work that is not described, please contact the Huber company.
- Maintenance work that is not described is reserved for qualified specialists trained by the Huber company.
- Safety-relevant components may only be replaced by equivalent components. The specified safety values for the respective component must be observed.

### 7.3.1 Function check and visual inspection

Control intervals

Cooling*	Description	Maintenance interval	Comment	Person responsible
A/W	Visually inspect hoses and hose connections	Prior to switching on the temperature control unit / accessory	Replace leaking hoses and hose connections before you switch on the temperature control unit / accessory. → Page 42, Section » <b>Replacing temperature control hoses</b> «.	Operating company and/or operators
A/W	Check the power cable	Prior to switching on the temperature control unit / accessory or when you change the installation location	Do not start up the temperature control unit / accessory if the power cable is damaged.	Qualified (certified) electrician
A/W	Heat transfer fluid inspection	As required	–	Operating company and/or operators
A/W	Inspect the accessory for damage and stability	Every 12 months or after relocation	–	Operating company and/or operators
A/W	Check the air filter mats	Determine according to ambient conditions.	Check all air filter mats at the accessory. Clean or replace the air filter mats as required. → Page 15, Section » <b>Proper disposal</b> «.	Operating company and/or operators
A/W	Exchange safety-relevant electric and electromechanical components	20 years	Have the exchange only carried out by certified personnel (such as Huber service engineers). Please contact Customer Support. → Page 47, Section » <b>Contact data</b> «	Operating company

\*A = Air cooling; W = Water cooling

### 7.3.2 Replacing temperature control hoses

Replace defective temperature control hoses **before** you switch on the temperature control unit / accessories.

#### PROCEDURE

- Exchange the temperature control hoses as described in the operation manual of the temperature control unit.

### 7.4 Heat transfer fluid inspection, replacement and circuit cleaning

#### PROCEDURE

- Do not disconnect the accessory.
- Proceed as described in the operation manual of the temperature control unit when performing the heat transfer fluid inspection and changing and cleaning the heat transfer fluid circuit.

### 7.5 Cleaning the surfaces



#### Extremely hot or cold surfaces, connections and heat transfer fluids BURNS OR FREEZING OF LIMBS

- Surfaces, connections and the tempered heat transfer fluid can be extremely hot or cold depending on the operating mode.
- Avoid direct contact!
- Wear personnel protective equipment. For example heat-resistant protective gloves and safety goggles.

**NOTE****Open plug contacts****DAMAGE CAUSED BY FLUID INGRESS**

- Protect plug contacts that are not required with the protective caps supplied.
- Clean surfaces only with a damp cloth.

A standard stainless steel cleaning agent is suitable for cleaning the stainless steel surfaces. Carefully clean painted surfaces (damp only) using a solution of sensitive-fabrics detergent. Observe the proper disposal of cleaning agents and aids. → Page 15, section »Proper disposal«.

## 7.6 Plug contacts

**NOTE****Open plug contacts****DAMAGE CAUSED BY FLUID INGRESS**

- Protect plug contacts that are not required with the protective caps supplied.
- Clean surfaces only with a damp cloth.

All plug contacts are provided with protective caps. Plug contacts that are not required must be protected with the protective caps.

## 7.7 Decontamination before shipping

**CAUTION****Shipping temperature control units or accessories that are not decontaminated****PERSONAL INJURIES AND DAMAGE DUE TO RESIDUES OF HAZARDOUS SUBSTANCES**

- Carry out suitable decontamination.
- The scope of decontamination depends on the type and amount of the substances used.
- The corresponding safety data sheet must be observed.
- You will find a prepared return receipt at [www.huber-online.com](http://www.huber-online.com).

The operating company is responsible for carrying out a decontamination. Decontamination must be carried out **before** the temperature control unit or accessory is shipped. For example for repair or inspection. It must be ensured that third-party personnel do **not** come into contact with a contaminated temperature control unit or accessory. A written note pointing out that decontamination has been carried out must be attached clearly visible on the temperature control unit or accessory.

To simplify the process, we have prepared a form for you. This is available for download at [www.huber-online.com](http://www.huber-online.com).

## 8 Shutting down

### 8.1 Safety instructions and basic principles

**DANGER**

**Connection/adjustment to the power supply not carried out by a qualified (certified) electrician and/or connection to a power socket without protective earth (PE)**

**MORTAL DANGER FROM ELECTRIC SHOCK**

- Have the connection/adjustment to the power supply carried out by a qualified (certified) electrician.
- Always connect the accessory to safety sockets (PE).

**DANGER**

**Damaged power cable/power cable connection**

**MORTAL DANGER FROM ELECTRIC SHOCK**

- Do not start up the accessory.
- Isolate the accessory from the power supply.
- Have the power cable/power cable connection replaced and inspected by a qualified (certified) electrician.

**WARNING**

**Risk of tipping due to unstable accessory**

**SEVERE INJURIES AND MATERIAL DAMAGE**

- Avoid risk of tipping due to unstable accessory.

**CAUTION**

**Non-compliance with the safety data sheet for the heat transfer fluid to be used**

**INJURIES**

- Risk of injury to the eyes, skin, respiratory tract.
- The safety data sheet for the heat transfer fluid to be used must be read prior to using it and its content must be respected.
- Observe the local regulations/work instructions.
- Wear your personal protective equipment (e.g. temperature-resistant safety gloves, safety goggles, safety footwear).
- Danger of slipping because floor and work area are contaminated. Clean the workplace; observe the proper disposal of heat transfer fluid and aids. → Page 15, section »Proper disposal«.

**CAUTION**

**Hot or very cold heat transfer fluid**

**SERIOUS BURNS/FREEZING OF LIMBS**

- Before draining, ensure that the heat transfer fluid has room temperature (20 °C).
- If, at this temperature, the heat transfer fluid is too viscous to be drained: Control the temperature of the heat transfer fluid for a few minutes until the viscosity will allow drainage.
- Danger of burns when draining heat transfer fluid at temperatures above 20 °C.
- Wear your personal protective equipment when carrying out the drainage operation.

**NOTE**

**The accessory is switched on or off while temperature control is ongoing**

**MATERIAL DAMAGE TO THE EXTERNAL APPLICATION**

- A system test is run when the accessory is switched on. If temperature control was active, this would cause the uncontrolled pressure to be applied to the external application. This must be avoided at all cost!
- Do not switch the accessory on or off while a temperature control process is active at the temperature control unit.
- The accessory may only be switched on or off if **no** temperature control is active at the temperature control unit.

**INFORMATION**

All safety instructions are important and must be followed accordingly during working operations!

## 8.2 Switch-off

### PROCEDURE

- Control the temperature of the heat transfer fluid to room temperature.
- Stop the control at the accessory. This closes the output. However the output cannot be completely closed due to the design.
- Stop the temperature control at the temperature control unit.
- Check whether the >Touchscreen< [88] at the accessory displays the value "0.0 %" during control mode. If the value is higher, the accessory may **not** be switched off!
- **Only valid for temperature control units and accessory with the function "Drain":**
  - . For the heat transfer fluid and/or cooling water circuit to be drained completely, the function "Drain" must be activated. For water-cooled temperature control units, this function also opens the control valve in the cooling water circuit, depending on the model. Skip the following instruction if the dialog entry "Drain" is not present:
    - Touch in succession "Category menu", "Temperature control", or "M-FCC", "Start/stop".
    - Touch the dialog entry: "Drain".
    - Confirm your choice by touching "OK".
    - Read the message and confirm by touching "OK".
    - Do **not** confirm the subsequent message by touching "OK".
- Turn off the temperature control unit. Please refer to the operation manual of the temperature control unit.
- Switch off the accessory.
- Disconnect the temperature control unit from the power supply. Please refer to the operation manual of the temperature control unit.
- Disconnect the accessory from the power supply.

## 8.3 Draining the accessory

### PROCEDURE

- Drain the temperature control unit and the accessory. → Page 36, section »Draining the accessory«.

## 8.4 Separating the accessory and the temperature control unit from the process control system

### PROCEDURE

- Disconnect the connection between temperature control unit and process control system.
- Disconnect the connection between accessory and process control system.

## 8.5 Separating the accessory from the temperature control unit

### PROCEDURE

- Drain the temperature control unit, the accessory and the external application **before** you dismantle the temperature control hoses.
- Switch off the temperature control unit and the accessory.
- Disconnect the temperature control unit and the accessory from the power grid connection.
- In case you use an external pressure sensor:
  - Disconnect the external pressure sensor from the >Signal external pressure sensor< [66] on the accessory.
- Disconnect the >Circulation return< [2'] on the accessory from the external application.
- Disconnect the >Circulation flow< [1'] on the accessory from the external application. Remove the overpressure protection device installed in the heat transfer fluid circuit, if present.
  - If you have used an external pressure sensor:
    - Remove the external pressure sensor from the heat transfer fluid circuit.
- Disconnect the >Circulation return< [2] on the temperature control unit from the >Circulation flow< [1] on the accessory.
- Disconnect the >Circulation flow< [1] on the temperature control unit from the >Circulation return< [2] on the accessory.
- Install the protective caps on the connections on the accessory.

## 8.6 Deactivating the leveling feet

Only valid for temperature control units with extendible leveling feet.

Ensure that the leveling feet are screwed in/deactivated before you pack the accessories.

### PROCEDURE

- Turn the red setting wheel on each caster counterclockwise. This retracts the leveling feet and activates the casters.
- Ensure that the locking brakes of the casters (if installed) are deactivated.

## 8.7 Packing

Always use the original packaging! → Page 19, section »Unpacking«.

## 8.8 Shipping

### NOTE

#### Improper transportation of the accessory

##### MATERIAL DAMAGE

- Do not transport the unit in a truck when the unit rests on its casters or leveling feet.
- Comply with all requirements in this section to avoid damage to the accessory.

Pallet with squared timber for free-standing units

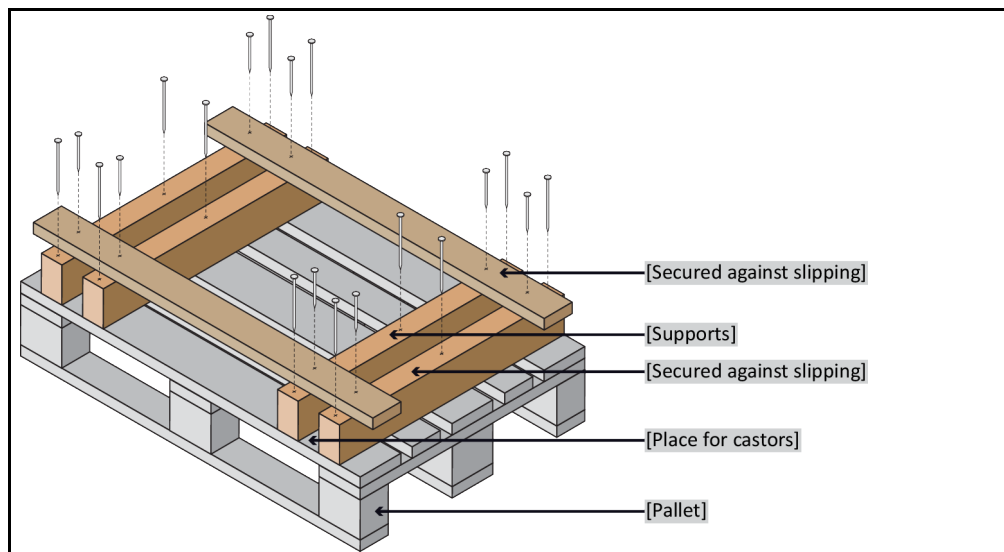

If fitted, use the lugs located on the top of the accessory for transportation. Do not transport the accessory alone and without aids.

- Always use the original packaging for transportation.
- Indicate the upright transport position with arrows on the packaging.
- Always transport the accessories upright on a pallet!
- Protect attachments from damage during transportation!
- During transportation, place the accessories on squared timber to protect the casters/feet.
- Secure with tensioning belts/lashing straps that are suitable for the weight.
- Additionally secure (depending on model) with plastic film, cardboard and straps.

## 8.9 Disposal

The operating company must observe the national and local regulations for the disposal

### NOTE

#### Improper disposal

##### ENVIRONMENTAL DAMAGE

- Immediately dispose of spilled or leaked heat transfer fluid in a professional manner. → Page 15, Section »**Proper disposal**«.
- Environmental damage must be avoided.
- Only commission approved specialized companies in the field of cooling and air-conditioning to carry out the disposal.

Huber temperature control units and Huber accessories are manufactured from high quality, recyclable materials. For example: Stainless steel 1.4301 / 1.4401 (V2A), copper, nickel, FKM, Perbunan, NBR, ceramic, carbon, Al-Oxid, red brass, brass, nickel-plated brass and silver solder. With proper recycling you actively contribute to the reduction of the CO<sub>2</sub> emissions during the manufacture of these materials.

## 8.10 Contact data

### INFORMATION

Please contact your supplier and/or local dealer **before** you return your accessories. The contact information can be found "Contact" on our home page [www.huber-online.com](http://www.huber-online.com). Please have the serial number of the accessories ready. The serial number can be found on the rating plate of the accessories.

### 8.10.1 Telephone number: Customer Support

If your country is not mentioned in the list below: The responsible service partner can be found on our homepage [www.huber-online.com](http://www.huber-online.com) under the heading „Contact“.

- Huber Deutschland: +49 781 9603 244
- Huber China: +86 (20) 89001381
- Huber India: +91 80 2364 7966
- Huber Ireland: +44 1773 82 3369
- Huber Italia: +39 0331 181493
- Huber Swiss: +41 (0) 41 854 10 10
- Huber UK: +44 1773 82 3369
- Huber USA: +1 800 726 4877 | +1 919 674 4266

### 8.10.2 Telephone number: Sales

Telephone: +49-781-9603-123

### 8.10.3 Email address: Customer Support

Email: [support@huber-online.com](mailto:support@huber-online.com)

## 8.11 Clearance certificate

This certificate must be enclosed with the temperature control unit. → Page 43, section »**Decontamination before shipping**«.

## 9 Annex



# Inspired by **temperature** designed for you

Peter Huber Kältemaschinenbau SE  
Werner-von-Siemens-Str. 1  
77656 Offenburg / Germany

Telefon +49 (0)781 9603-0  
Telefax +49 (0)781 57211

[info@huber-online.com](mailto:info@huber-online.com)  
[www.huber-online.com](http://www.huber-online.com)

Technischer Service: +49 (0)781 9603-244

-125 °C ... +425 °C

**huber**